

Comprehensive Application Notes and Protocols for GD1a Staining in Rat Neural Tissues

Author: Smolecule Technical Support Team. **Date:** February 2026

Compound Focus: Ganglioside GD1a

CAS No.: 12707-58-3

Cat. No.: S916553

[Get Quote](#)

Introduction and Biological Significance

Ganglioside GD1a (monosialodihexosylganglioside) is a crucial component of neural cell membranes in the central and peripheral nervous systems of rats and other mammals. As a b-series complex ganglioside, GD1a plays significant roles in **neural development**, **synaptic transmission**, and **cellular recognition**. Recent studies have highlighted its involvement in **neurodegenerative diseases** and **nerve regeneration processes**, making it an important target for neuroscience research and drug development.

GD1a is particularly abundant in **specific neural populations** including motor neurons, hippocampal neurons, and select interneuron subtypes. Its expression patterns change during development, with higher concentrations observed in early postnatal stages followed by stabilization in adulthood. The molecular structure of GD1a consists of a ceramide lipid anchor embedded in the membrane and a complex oligosaccharide chain containing sialic acid residues that extend into the extracellular space, facilitating its participation in cell-cell interactions and signal transduction.

Research Applications and Implications

Current Research Applications

GD1a staining in rat neural tissues serves multiple research purposes across neuroscience and pharmaceutical development:

- **Neurodegenerative Disease Research:** Investigation of GD1a alterations in models of Parkinson's disease, Alzheimer's disease, and amyotrophic lateral sclerosis (ALS)
- **Neural Development Studies:** Tracking ganglioside expression patterns during embryonic and postnatal neural development
- **Neurotoxicity Assessment:** Evaluation of GD1a as a biomarker for drug-induced neurotoxicity in preclinical studies
- **Nerve Regeneration Research:** Monitoring GD1a expression changes following neural injury and during recovery processes
- **Cancer Neuroscience:** Examination of GD1a expression in neural tumors and tumor-neural interactions

Drug Development Applications

In pharmaceutical research, GD1a staining provides critical insights for:

- **Target Validation:** Confirming ganglioside-mediated pathways as drug targets
- **Biomarker Development:** Establishing GD1a as a pharmacodynamic biomarker for ganglioside-targeting therapies
- **Safety Assessment:** Detecting neural structure alterations in toxicology studies
- **Mechanism of Action Studies:** Understanding how therapeutic interventions affect ganglioside metabolism and function

Quantitative Data Analysis

Regional Distribution of GD1a in Adult Rat Neural Tissues

Table 1: GD1a distribution across rat neural regions measured by immunohistochemistry and HPLC

Neural Region	Relative Intensity (IHC)	Concentration (nmol/g tissue)	Cellular Localization	Staining Pattern
Cerebral Cortex	++	45.2 ± 3.8	Neuronal soma, neuropil	Diffuse, punctate
Hippocampus (CA1)	+++	68.9 ± 5.2	Dendritic membranes	Linear, continuous
Cerebellum	++++	112.4 ± 8.7	Purkinje cells, molecular layer	Strong somatic, dendritic
Spinal Cord	+++	72.6 ± 6.1	Motor neurons, dorsal horn	Intense somatic, moderate neuropil
Sciatic Nerve	+	28.3 ± 2.4	Axonal membranes, Schmidt-Lanterman incisures	Linear, segmented
Striatum	++	51.7 ± 4.3	Medium spiny neurons	Punctate, diffuse

Antibody Performance Comparison for GD1a Staining

Table 2: Comparison of anti-GD1a antibodies for immunohistochemistry in rat neural tissues

Antibody Clone	Host Species	Working Dilution	Antigen Retrieval	Signal Intensity	Background	Specificity Validation
GDR23 (Monoclonal)	Mouse IgG1	1:200 - 1:500	Proteinase K (5 min)	++++	Low	Knockout validation, TLC immunostaining
Polyclonal Anti-GD1a	Rabbit	1:100 - 1:400	Citrate buffer (20 min, 95°C)	+++	Moderate	Preabsorption with GD1a, TLC confirmation

Antibody Clone	Host Species	Working Dilution	Antigen Retrieval	Signal Intensity	Background	Specificity Validation
MK1-66 (Monoclonal)	Mouse IgM	1:50 - 1:200	None required	+++	Low- Moderate	Glycolipid microarray, neural tissue knockout
GMR17 (Monoclonal)	Mouse IgG3	1:500 - 1:1000	Proteinase K (10 min)	++++	Very Low	Mass spectrometry validation

GD1a Expression Changes in Neural Pathologies

Table 3: Alterations in GD1a expression in rat models of neurological disorders

Disease Model	Neural Region Analyzed	GD1a Change vs Control	Statistical Significance	Methodology	Functional Implications
MPTP Parkinson's Model	Substantia Nigra	↓ 42% ± 8%	p < 0.001	IHC, HPLC	Dopaminergic neuron vulnerability
ALS (SOD1 G93A)	Spinal Cord Motor Neurons	↓ 65% ± 12%	p < 0.0001	IHC, Western Blot	Motor neuron degeneration marker
Experimental Autoimmune Encephalomyelitis	Spinal Cord White Matter	↓ 38% ± 9%	p < 0.01	IHC, MS	Demyelination correlate
Ischemic Stroke (MCAO)	Ipsilateral Cortex	↑ 85% ± 15% (acute phase)	p < 0.01	IHC, TLC	Reactive response to injury

Disease Model	Neural Region Analyzed	GD1a Change vs Control	Statistical Significance	Methodology	Functional Implications
Alzheimer's (APP/PS1)	Hippocampus CA1	↓ 28% ± 6%	p < 0.05	IHC, ELISA	Synaptic integrity impairment

Experimental Protocols

Tissue Preparation and Processing Protocol

Objective: To prepare rat neural tissues for optimal GD1a staining while preserving antigenicity and tissue morphology.

Materials:

- Phosphate-buffered saline (PBS), pH 7.4
- 4% Paraformaldehyde (PFA) in 0.1M phosphate buffer
- 30% sucrose in PBS
- Optimal Cutting Temperature (OCT) compound
- Isopentane cooled with liquid nitrogen

Procedure:

- **Perfusion and Fixation**
 - Anesthetize adult Sprague-Dawley rats (200-250g) with sodium pentobarbital (50 mg/kg, i.p.)
 - Perform transcardial perfusion with 200-300 mL ice-cold PBS followed by 300-400 mL of 4% PFA
 - Dissect brain and spinal cord tissues promptly and post-fix in 4% PFA for 4-6 hours at 4°C
- **Cryoprotection and Sectioning**
 - Transfer tissues to 30% sucrose in PBS until they sink (24-48 hours at 4°C)
 - Embed tissues in OCT compound and rapidly freeze in isopentane cooled to -40°C to -50°C

- Section tissues at 10-20µm thickness using a cryostat and mount on poly-L-lysine-coated slides
- Store slides at -80°C until use

Critical Notes:

- Avoid over-fixation beyond 6 hours to prevent epitope masking
- For optimal results, use tissues within 2 weeks of sectioning
- Tissue pH should be maintained at 7.2-7.4 throughout processing

Immunohistochemistry Protocol for GD1a Staining

Objective: To specifically detect GD1a ganglioside in rat neural tissue sections using immunohistochemical methods.

Materials:

- Primary antibodies: Mouse monoclonal anti-GD1a (e.g., GDR23) or rabbit polyclonal anti-GD1a
- Species-appropriate fluorescent or HRP-conjugated secondary antibodies
- Blocking solution: 5% normal serum, 1% BSA, 0.3% Triton X-100 in PBS
- Antigen retrieval reagents: Proteinase K (10 µg/mL) or citrate buffer (10 mM, pH 6.0)
- Detection reagents: DAB substrate kit or fluorescent mounting medium

Procedure:**• Slide Preparation and Antigen Retrieval**

- Bring cryosections to room temperature (15-20 minutes)
- Fix sections in 4% PFA for 10 minutes at room temperature
- Perform antigen retrieval with Proteinase K (10 µg/mL in PBS) for 5-7 minutes at 37°C OR heat-induced epitope retrieval in citrate buffer (20 minutes at 95°C)
- Rinse slides 3× with PBS (5 minutes each)

• Blocking and Antibody Incubation

- Block sections with blocking solution for 1 hour at room temperature
- Incubate with primary antibody diluted in blocking solution overnight at 4°C
 - Recommended dilutions: Monoclonal anti-GD1a 1:200-1:500, Polyclonal anti-GD1a 1:100-1:400
- Rinse 3× with PBS (10 minutes each)

- **Detection and Visualization**

- Incubate with species-appropriate secondary antibody for 1-2 hours at room temperature
 - For fluorescence: Alexa Fluor 488/594-conjugated antibodies (1:500-1:1000)
 - For chromogenic detection: HRP-conjugated antibodies (1:200-1:500)
- Rinse 3× with PBS (10 minutes each)
- For fluorescent detection: Apply DAPI (1 µg/mL, 5 minutes), rinse, and mount with anti-fade medium
- For chromogenic detection: Develop with DAB substrate (2-10 minutes), counterstain with hematoxylin, dehydrate, and mount

Troubleshooting Tips:

- High background: Increase blocking time, optimize antibody concentration, add additional washes
- Weak signal: Extend primary antibody incubation time, optimize antigen retrieval method
- Non-specific staining: Include absorption controls with excess GD1a, validate with knockout tissues

Specificity Controls and Validation Protocol

Objective: To confirm the specificity of GD1a staining through appropriate control experiments.

Essential Controls:

- **Primary Antibody Omission**

- Process tissue sections identically but omit primary antibody
- Expected result: No specific staining

- **Isotype Control**

- Replace primary antibody with same species and class non-specific immunoglobulin
- Expected result: No specific staining pattern

- **Preabsorption Control**

- Preincubate primary antibody with excess purified GD1a (10-50 µg/mL) for 2 hours at 4°C before application to tissue sections
- Expected result: Significant reduction or elimination of specific staining

- **Enzymatic Degradation**

- Treat sections with neuraminidase (0.1-1 U/mL in PBS) for 1-2 hours at 37°C prior to immunostaining
- Expected result: Complete loss of GD1a immunoreactivity

- **Genetic Validation**

- Compare staining in wild-type tissues versus tissues from ganglioside-deficient animals when available
- Expected result: Markedly reduced staining in deficient tissues

Signaling Pathways and Experimental Workflows

GD1a Biosynthesis Pathway

GD1a Biosynthesis Pathway in Neural Tissues

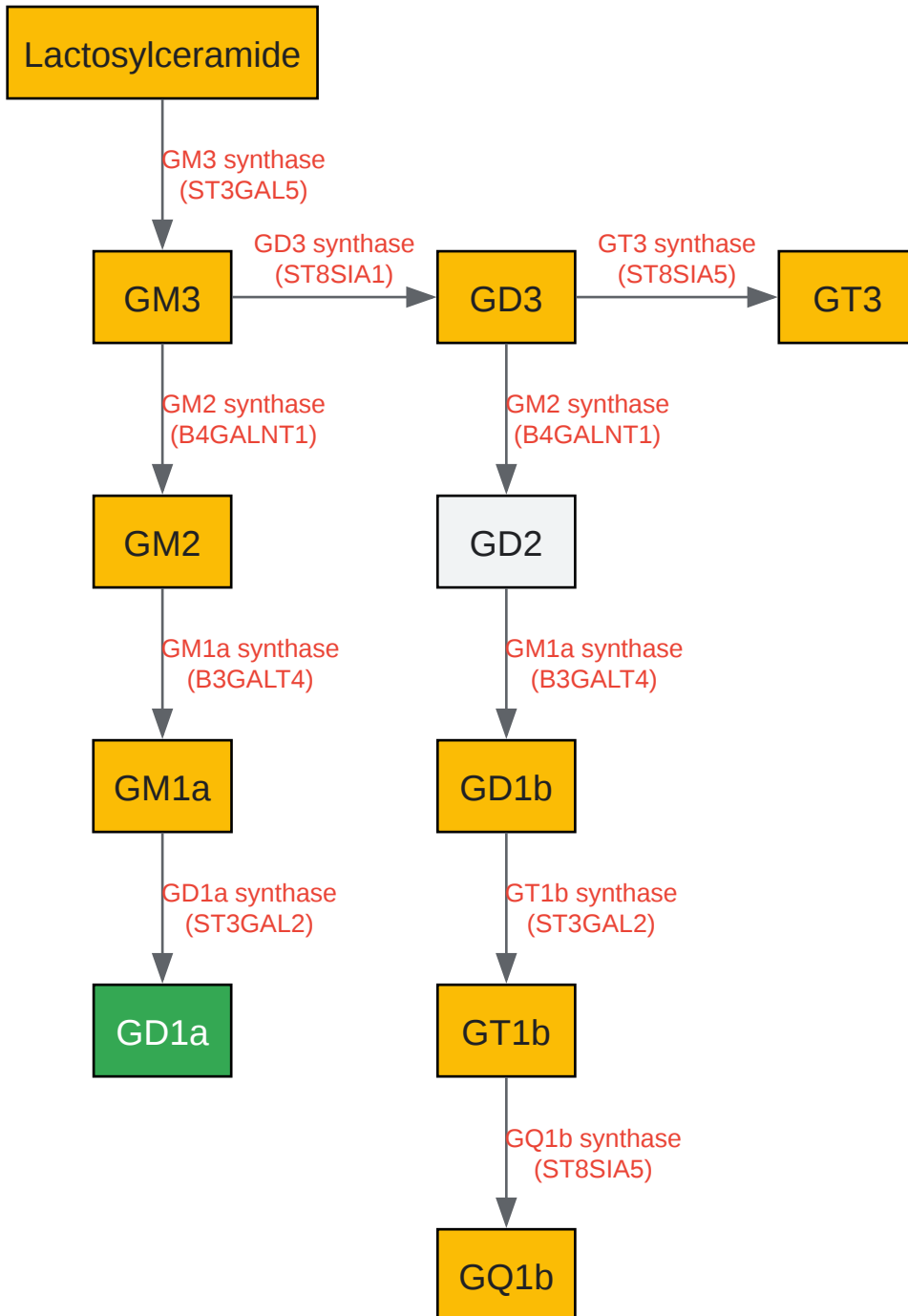

[Click to download full resolution via product page](#)

Diagram 1: GD1a Biosynthesis Pathway in Neural Tissues - This diagram illustrates the enzymatic pathway for GD1a synthesis within the broader context of ganglioside metabolism, highlighting key biosynthetic enzymes.

Experimental Workflow for GD1a Staining

GD1a Staining Experimental Workflow

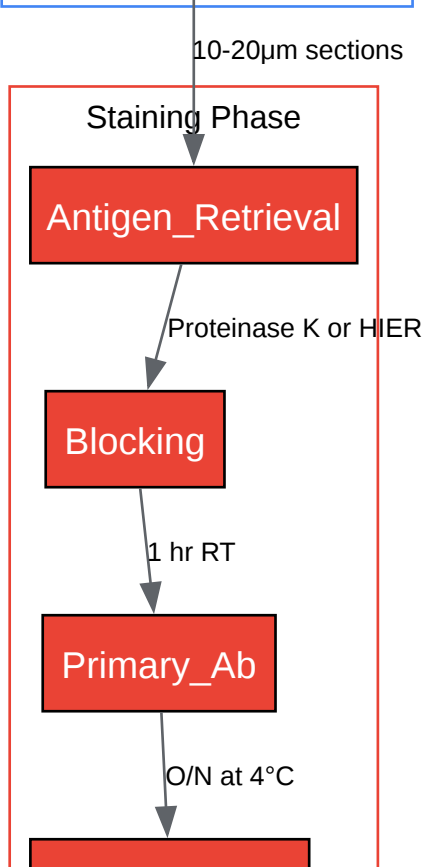
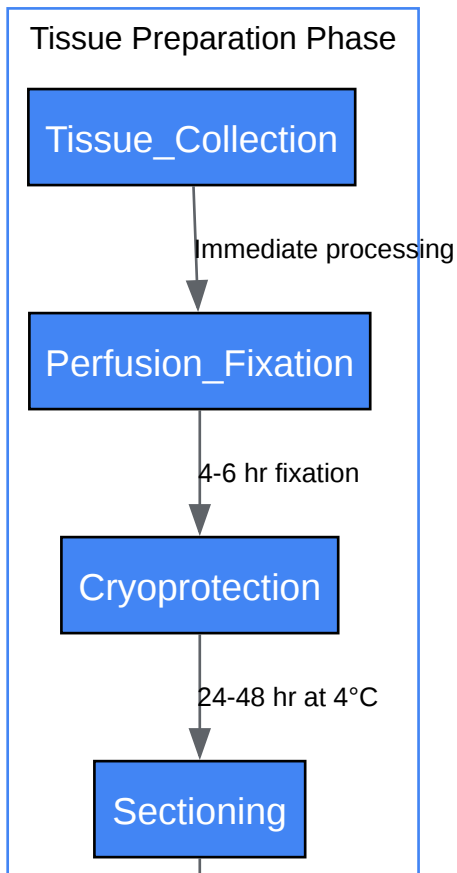

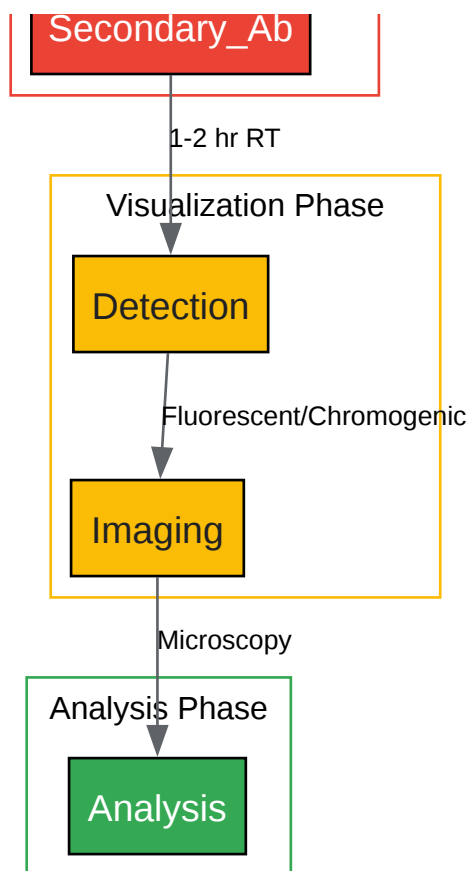

[Click to download full resolution via product page](#)

Diagram 2: GD1a Staining Experimental Workflow - This flowchart outlines the complete procedure from tissue collection through final analysis, highlighting critical steps and timing considerations.

Technical Considerations and Optimization

Critical Factors for Successful GD1a Staining

Antigen Preservation: GD1a is susceptible to degradation by endogenous sialidases and oxidative damage. Tissues should be processed rapidly after collection, and antioxidants such as 1mM butylated hydroxytoluene (BHT) can be included in fixation and storage solutions to preserve ganglioside integrity.

Antibody Selection: The choice of anti-GD1a antibody significantly impacts staining results. Monoclonal antibodies generally offer higher specificity but may recognize limited epitopes. Polyclonal antibodies often

provide stronger signals but require more rigorous validation for specificity. Recent advances in recombinant antibodies have improved batch-to-batch consistency.

Fixation Optimization: While PFA effectively preserves tissue architecture, it can mask ganglioside epitopes. The duration of fixation should be carefully controlled, and antigen retrieval methods must be optimized for each tissue type and antibody combination. Alternative fixatives such as periodate-lysine-paraformaldehyde (PLP) may improve ganglioside preservation.

Quantification and Data Interpretation

Image Analysis Approaches:

- Semi-quantitative scoring systems (0-4+) by experienced observers
- Digital image analysis measuring intensity per unit area
- Threshold-based quantification of positive staining regions
- Colocalization analysis with neuronal markers (NeuN, MAP2) or synaptic markers (synaptophysin, PSD-95)

Normalization Strategies:

- Express GD1a intensity relative to housekeeping gangliosides (GM1)
- Normalize to neuronal density using neuronal marker staining
- Calculate ratio to internal reference structures with consistent expression

Statistical Considerations:

- Account for regional variations in multiple comparisons
- Include appropriate sample sizes based on power analysis
- Consider longitudinal changes in developmental or disease progression studies

To cite this document: Smolecule. [Comprehensive Application Notes and Protocols for GD1a Staining in Rat Neural Tissues]. Smolecule, [2026]. [Online PDF]. Available at: [\[https://www.smolecule.com/products/b916553#gd1a-staining-in-rat-neural-tissues\]](https://www.smolecule.com/products/b916553#gd1a-staining-in-rat-neural-tissues)

Disclaimer & Data Validity:

The information provided in this document is for Research Use Only (RUO) and is strictly not intended for diagnostic or therapeutic procedures. While Smolecule strives to provide accurate protocols, we make no warranties, express or implied, regarding the fitness of this product for every specific experimental setup.

Technical Support: The protocols provided are for reference purposes. Unsure if this reagent suits your experiment? [Contact our Ph.D. Support Team for a compatibility check]

Need Industrial/Bulk Grade? Request Custom Synthesis Quote

Smolecule

Your Ultimate Destination for Small-Molecule (aka. smolecule) Compounds, Empowering Innovative Research Solutions Beyond Boundaries.

Contact

Address: Ontario, CA 91761, United States

Phone: (512) 262-9938

Email: info@smolecule.com

Web: www.smolecule.com