

Molecular Docking Studies of Fluindapyr with Succinate Dehydrogenase: Application Notes and Experimental Protocols

Author: Smolecule Technical Support Team. **Date:** February 2026

Compound Focus: Fluindapyr

CAS No.: 1383809-87-7

Cat. No.: S892978

[Get Quote](#)

Introduction to Fluindapyr and the SDH Molecular Target

Fluindapyr is a novel **broad-spectrum chiral fungicide** belonging to the succinate dehydrogenase inhibitor (SDHI) class, developed to control economically significant fungal pathogens in various crops. As a pyrazole-4-carboxamide derivative, it contains a chiral center resulting in two enantiomers (R- and S-**fluindapyr**) that demonstrate **strikingly different biological activities** [1]. The molecular target of **fluindapyr** is **succinate dehydrogenase (SDH)**, also known as mitochondrial Complex II, a critical enzymatic complex located in the inner mitochondrial membrane. This essential enzyme occupies a unique position in cellular metabolism by serving dual roles in both the **tricarboxylic acid (TCA) cycle** and the **electron transport chain** [2]. SDH catalyzes the oxidation of succinate to fumarate in the TCA cycle while simultaneously transferring electrons directly to ubiquinone in the respiratory chain, making it indispensable for cellular energy production [3].

The SDH enzyme complex consists of four protein subunits (SDHA, SDHB, SDHC, and SDHD), with the **quinone-binding site (Q-site)** formed at the interface of the SDHB, SDHC, and SDHD subunits serving as the specific molecular target for SDHI fungicides [2] [3]. The high degree of evolutionary conservation in the structure and amino acid sequence of the Q-site across diverse species, including fungi, animals, and

humans, explains why SDHIs like **fluindapyr** can potentially affect non-target organisms [2]. Recent studies have revealed that the **enantioselective activity** of **fluindapyr** stems from differential binding of its R- and S-forms to this Q-site, with **S-fluindapyr** demonstrating 87.8 times greater activity against *Rhizoctonia solani* compared to the R-enantiomer [1]. This pronounced enantioselectivity, combined with the widespread agricultural use of SDHI fungicides, underscores the critical importance of molecular docking studies to understand the structural basis of these interactions and guide the development of more selective and effective fungicidal agents.

Molecular Docking Protocol with Fluindapyr

System Preparation

Table 1: Components for Molecular Docking System Preparation

Component	Specification	Purpose	Reference
Protein Preparation	SDH structure (e.g., from <i>R. solani</i>)	Provide molecular target	[1]
Ligand Preparation	R- and S-fluindapyr structures	Investigate enantioselective binding	[1]
Docking Software	Molecular docking suite (e.g., AutoDock, Schrödinger)	Perform computational docking	[1]
Visualization Tools	PyMOL, Chimera, Discovery Studio	Analyze binding interactions	[1] [4]

Protein Structure Preparation: Begin by obtaining the three-dimensional structure of the succinate dehydrogenase complex. If an experimental crystal structure is unavailable, utilize **homology modeling** approaches to generate a reliable protein model based on related structures. The critical focus should be on the **quinone-binding pocket** (Q-site) formed at the interface of the SDHB, SDHC, and SDHD subunits. Process the protein structure by removing water molecules and co-crystallized ligands, adding hydrogen

atoms, assigning appropriate protonation states to amino acid residues, and optimizing hydrogen bonding networks [1] [3].

Ligand Structure Preparation: Obtain the three-dimensional structures of both R- and S-**fluindapyr** enantiomers. If experimental structures are unavailable, employ **computational chemistry software** to generate energetically optimized conformations. Ensure proper assignment of **chiral centers** and electrostatic parameters. Conduct geometry optimization using semi-empirical or density functional theory (DFT) methods to obtain accurate three-dimensional representations of both enantiomers [1] [5]. Prepare the ligands for docking by assigning appropriate atomic charges and identifying rotatable bonds.

Docking Methodology

Table 2: Molecular Docking Parameters for **Fluindapyr**-SDH Studies

Parameter	Setting	Rationale
Grid Box Size	60 × 60 × 60 points	Encompass entire Q-site with margin
Grid Spacing	0.375 Å	Balance between precision and computational cost
Docking Algorithm	Lamarckian Genetic Algorithm	Robust conformational sampling
Number of Runs	100 per enantiomer	Ensure statistical significance
Binding Interactions Analyzed	Hydrogen bonds, π -cation, hydrophobic	Key forces in enzyme-inhibitor recognition
Molecular Dynamics Follow-up	50-100 ns simulation	Assess binding stability and conformational changes

Docking Execution: Configure the docking search parameters to focus on the **quinone-binding site** of SDH, defining a grid box that encompasses the entire binding pocket with sufficient margin to allow for complete ligand flexibility. Perform molecular docking simulations for both R- and S-**fluindapyr** enantiomers using identical parameters to enable direct comparison. Utilize **semi-flexible docking**

approaches that treat the ligand as flexible while maintaining protein rigidity, or consider **flexible receptor docking** if computational resources permit [1] [4].

Interaction Analysis: Following docking simulations, analyze the resulting binding poses for both enantiomers. Identify specific **protein-ligand interactions** including hydrogen bonds, π -cation interactions, hydrophobic contacts, and van der Waals forces. Pay particular attention to interactions with conserved residues in the Q-site that are known to be critical for inhibitor binding. Compare the **binding orientations** and interaction patterns of the two enantiomers to elucidate the structural basis for experimentally observed differences in biological activity [1].

Molecular Docking Workflow for Fluindapyr-SDH Studies

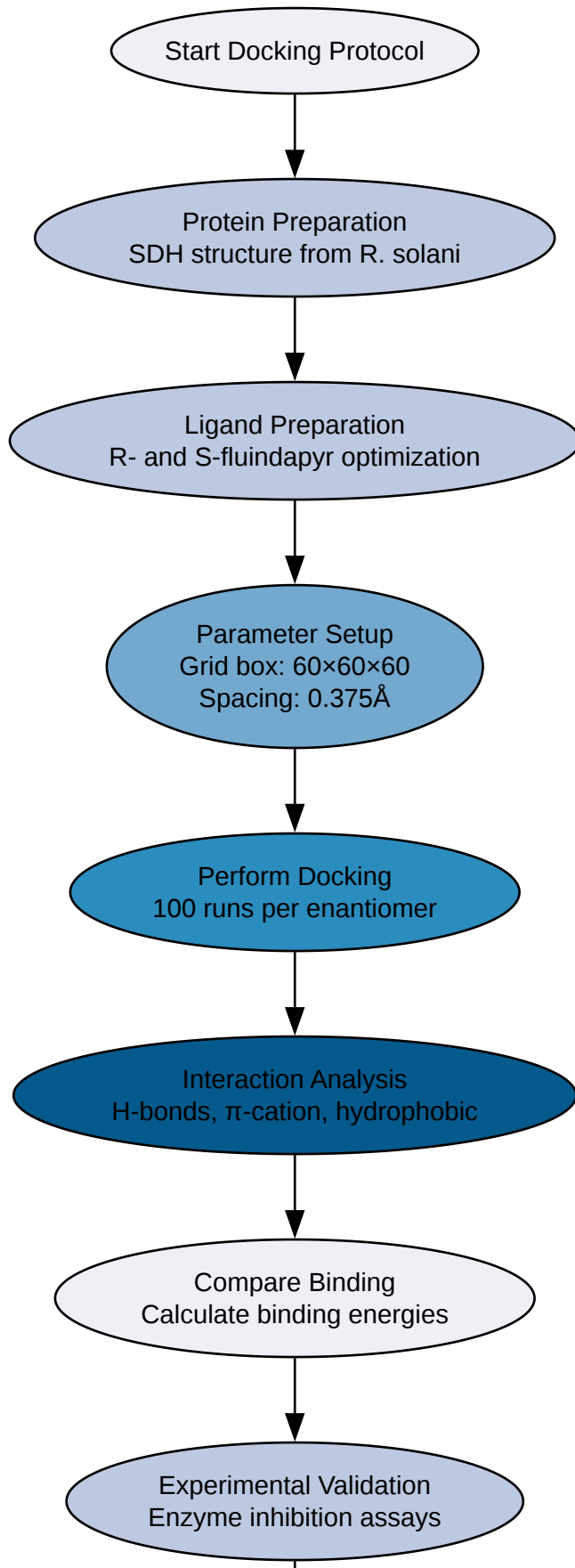

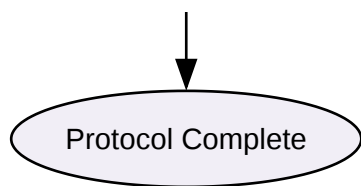

[Click to download full resolution via product page](#)

Experimental Protocol for Enzyme Activity Assays

SDH Enzyme Inhibition Assay

The **enzyme inhibition assay** provides experimental validation for the predictions derived from molecular docking studies by quantitatively measuring the functional impact of **fluindapyr** binding to SDH.

Mitochondrial Preparation: Isolate intact mitochondria from the target fungal pathogen (e.g., *Rhizoctonia solani*) using differential centrifugation techniques. Homogenize fungal mycelia in an isotonic buffer (e.g., 0.25 M sucrose, 10 mM Tris-HCl, 1 mM EDTA, pH 7.4) and centrifuge at low speed ($1,000 \times g$) to remove cellular debris. Collect the supernatant and centrifuge at higher speed ($12,000 \times g$) to pellet the mitochondrial fraction. Resuspend the mitochondrial pellet in appropriate assay buffer and determine protein concentration using standard methods (e.g., Bradford assay) [3].

SDH Activity Measurement: Assess SDH activity by monitoring the **reduction of 2,6-dichlorophenol-indophenol (DPIP)** at 600 nm using a UV-visible spectrophotometer. The assay principle relies on the transfer of electrons from succinate to DPIP via the electron transport chain, with PMS (phenazine methosulfate) serving as an intermediate electron carrier. Prepare reaction mixtures containing 50 mM phosphate buffer (pH 7.4), 0.01% DPIP, 0.05% PMS, 20 mM succinate, and various concentrations of R- and S-**fluindapyr** (typically ranging from 0.1 to 100 $\mu\text{g}/\text{mL}$). Initiate the reaction by adding the mitochondrial preparation (50-100 μg protein) and immediately monitor the decrease in absorbance at 600 nm for 3-5 minutes [3].

Data Analysis: Calculate SDH activity as the rate of DPIP reduction, expressed as nmol DPIP reduced per minute per mg protein. Determine the **percentage inhibition** at each fungicide concentration compared to untreated controls. Calculate IC_{50} values (concentration causing 50% inhibition) for both enantiomers using non-linear regression analysis of inhibition curves. These experimental values should be correlated with

computational binding energies obtained from molecular docking studies to validate the docking predictions [1] [3].

Enantioselective Degradation Studies in Paddy Ecosystems

Sample Preparation: For environmental fate studies, develop a reliable extraction and quantification method for **fluidapyr** enantiomers in soil matrices. The **QuEChERS** (Quick, Easy, Cheap, Effective, Rugged, and Safe) approach utilizing **husk-based biochar material** as a purification sorbent has been successfully employed for paddy soil samples. Optimize the extraction solvent composition (typically acetonitrile with 1% acetic acid) and the amount of biochar sorbent to achieve maximum recovery with minimal matrix interference [1].

Chiral Separation and Quantification: Separate **fluidapyr** enantiomers using **ultra-high performance liquid chromatography tandem mass spectrometry (UPLC-MS/MS)** with chiral stationary phases. The MX(2)-RH column has demonstrated effective baseline separation of **fluidapyr** enantiomers under reversed-phase conditions. Establish chromatographic conditions that provide clear resolution of both enantiomers, typically using acetonitrile/water mobile phases with modifiers such as formic acid or ammonium acetate. Confirm enantiomer identity by comparing retention times with individually prepared enantiomer standards and determine absolute configuration using **electron circular dichroism** [1] [5].

Degradation Kinetics: Conduct anaerobic degradation studies in paddy soil to investigate enantioselective degradation patterns. Incubate soil samples fortified with racemic **fluidapyr** under controlled conditions (e.g., 25°C in the dark). Collect samples at predetermined time intervals, extract residual **fluidapyr** enantiomers, and quantify using the established UPLC-MS/MS method. Calculate **half-lives** for each enantiomer using first-order kinetics and determine the **enantiomer fraction** throughout the incubation period to quantify enantioselectivity in degradation [1].

Data Analysis and Validation

Interpretation of Docking Results

Binding Energy Calculations: The primary quantitative output from molecular docking studies is the **calculated binding energy**, which provides a predictive measure of inhibitor potency. For **fluindapyr** enantiomers, studies have revealed significantly different binding energies to SDH: -32.12 kcal/mol for R-**fluindapyr** compared to -42.91 kcal/mol for S-**fluindapyr** [1]. This substantial difference in binding affinity correlates with the observed 87.8-fold greater bioactivity of S-**fluindapyr** against *Rhizoctonia solani* compared to the R-enantiomer. When analyzing docking results, focus not only on the overall binding energy but also decompose these values into contributions from specific interaction types to identify the structural features responsible for binding differences.

Interaction Mapping: Detailed analysis of the specific protein-ligand interactions provides mechanistic insights into the enantioselective binding. For **fluindapyr**, the superior binding of the S-enantiomer is attributed to more favorable **hydrogen bonding patterns**, enhanced **π -cation interactions**, and optimized **hydrophobic contacts** with key residues in the Q-site [1] [4]. Create comprehensive interaction diagrams that visualize these contacts and quantify their relative contributions to the overall binding energy. Compare the binding orientations of both enantiomers to identify specific amino acid residues that discriminate between them, as these residues represent potential targets for rational design of more selective inhibitors.

Experimental Validation Methods

Biological Activity Assay: Validate computational predictions by determining the **in vitro antifungal activity** of **fluindapyr** enantiomers against target pathogens. For *Rhizoctonia solani*, prepare PDA (Potato Dextrose Agar) media amended with serial dilutions of individual **fluindapyr** enantiomers. Inoculate plates with mycelial plugs and measure colony growth after incubation at 28°C. Calculate EC₅₀ values (effective concentration for 50% growth inhibition) for both enantiomers, which should demonstrate significant differences consistent with the computational predictions [1].

Enzyme Inhibition Kinetics: Correlate binding energies with functional inhibition by determining IC₅₀ values for SDH enzyme inhibition. As demonstrated in similar SDHI studies, excellent inhibitors like SYP-32497 can achieve IC₅₀ values as low as 0.300 µg/mL, while less potent inhibitors may show significantly higher values (e.g., 1.266 µg/mL for fluxapyroxad) [3]. Establish a correlation plot between computational binding energies and experimental IC₅₀ values to validate the predictive power of the docking protocol.

SDH Inhibition Mechanism of Fluindapyr

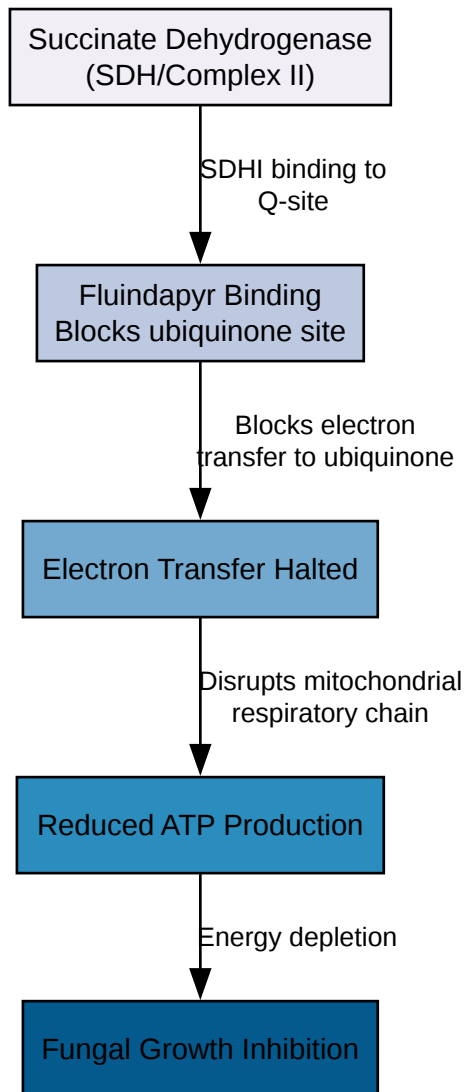

[Click to download full resolution via product page](#)

Table 3: Experimental Validation Parameters for **Fluindapyr**-SDH Interaction Studies

Validation Method	Key Parameters	Expected Outcome	Acceptance Criteria
Enzyme Inhibition	IC ₅₀ values, Ki determination	S-fluindapyr IC ₅₀ << R-fluindapyr IC ₅₀	Minimum 10-fold difference
Antifungal Activity	EC ₅₀ against R. solani	S-fluindapyr more potent	Consistent with enzyme data

Validation Method	Key Parameters	Expected Outcome	Acceptance Criteria
Binding Kinetics	KD, kon, koff measurements	Tighter binding for S-fluindapyr	Correlation with docking energies
Environmental Degradation	Half-lives in soil	Differential degradation	R-fluindapyr degrades faster

Applications and Future Directions

The integrated molecular docking and experimental validation protocols outlined in this document provide a robust framework for investigating the **enantioselective interactions** between chiral SDHI fungicides and their target enzyme. These approaches have revealed crucial structure-activity relationship information for **fluindapyr**, particularly the dramatic enantioselectivity in both binding affinity and biological activity [1]. The methodology enables **rational design** of next-generation SDHI fungicides with optimized target binding, potentially leading to improved efficacy and reduced application rates. Furthermore, understanding the molecular basis of enantioselectivity can guide the development of single-enantiomer products that minimize environmental loading while maintaining effective disease control.

Future applications of these protocols should address several emerging challenges in SDHI research. The **development of resistance** in fungal pathogens represents a significant threat to SDHI efficacy, necessitating docking studies with mutant forms of SDH containing known resistance mutations [3]. Additionally, the **potential effects on non-target organisms** warrant careful investigation, given the evolutionary conservation of the SDH complex across species [2] [6]. Molecular docking studies comparing fungal and mammalian SDH structures could identify selectivity determinants that might be exploited to design fungicides with reduced ecological impact. The integration of **molecular dynamics simulations** with docking studies would provide insights into binding stability and conformational changes that static docking alone cannot capture. Finally, these protocols can be adapted for **investigation of other chiral SDHs**, such as penthiopyrad, which also demonstrate enantioselective behavior [5].

Conclusion

The application notes and protocols presented herein provide a comprehensive framework for conducting molecular docking studies of **fluindapyr** with succinate dehydrogenase, complemented by experimental validation methods. The **integrated computational and experimental approach** enables researchers to elucidate the structural basis of enantioselective binding and activity observed with chiral SDHI fungicides. Key findings from **fluindapyr** studies include the significantly stronger binding of S-**fluindapyr** to SDH (-42.91 kcal/mol) compared to the R-enantiomer (-32.12 kcal/mol), which correlates with its superior antifungal efficacy [1]. The methodologies described facilitate the translation of structural insights into practical strategies for improving fungicide design, environmental safety profiling, and resistance management. By implementing these standardized protocols, researchers can generate comparable, reproducible data that advances our understanding of SDHI fungicide interactions at the molecular level and contributes to the development of more sustainable crop protection solutions.

Need Custom Synthesis?

Email: info@smolecule.com or Request Quote Online.

References

1. Enantioselective Degradation and Bioactivity Mechanism ... [pubmed.ncbi.nlm.nih.gov]
2. SDHI Fungicide Toxicity and Associated Adverse Outcome ... [pmc.ncbi.nlm.nih.gov]
3. Baseline Sensitivity to and Succinate Dehydrogenase ... [mdpi.com]
4. Design, Synthesis, Antifungal Evaluation, Structure–Activity ... [pmc.ncbi.nlm.nih.gov]
5. dehydrogenase-inhibitor fungicides in plant-origin foods ... [sciencedirect.com]
6. SDHI Fungicide Toxicity and Associated Adverse Outcome ... [pubmed.ncbi.nlm.nih.gov]

To cite this document: Smolecule. [Molecular Docking Studies of Fluindapyr with Succinate Dehydrogenase: Application Notes and Experimental Protocols]. Smolecule, [2026]. [Online PDF]. Available at: [<https://www.smolecule.com/products/b892978#molecular-docking-study-fluindapyr-succinate-dehydrogenase>]

Disclaimer & Data Validity:

The information provided in this document is for Research Use Only (RUO) and is strictly not intended for diagnostic or therapeutic procedures. While Smolecule strives to provide accurate protocols, we make no warranties, express or implied, regarding the fitness of this product for every specific experimental setup.

Technical Support: The protocols provided are for reference purposes. Unsure if this reagent suits your experiment? [Contact our Ph.D. Support Team for a compatibility check]

Need Industrial/Bulk Grade? Request Custom Synthesis Quote

Smolecule

Your Ultimate Destination for Small-Molecule (aka. smolecule) Compounds, Empowering Innovative Research Solutions Beyond Boundaries.

Contact

Address: Ontario, CA 91761, United States

Phone: (512) 262-9938

Email: info@smolecule.com

Web: www.smolecule.com