

Comprehensive Application Notes and Protocols for Native Chemical Ligation with Dbz Peptides

Author: Smolecule Technical Support Team. **Date:** February 2026

Compound Focus: Fmoc-Dbz(o-Alloc)-OH

CAS No.: 2143465-53-4

Cat. No.: S6576694

[Get Quote](#)

Introduction to Dbz Linker Chemistry in Native Chemical Ligation

Native Chemical Ligation (NCL) has revolutionized chemical protein synthesis by enabling the chemoselective condensation of unprotected peptide fragments through a reaction between a C-terminal thioester and an N-terminal cysteine residue, forming a native peptide bond at the ligation site [1]. This powerful methodology allows researchers to access synthetic proteins and post-translationally modified proteins that are challenging to produce using recombinant methods. The **development of thioester surrogates** compatible with standard Fmoc-SPPS (Solid Phase Peptide Synthesis) has been crucial for advancing NCL applications, as traditional thioester synthesis faces compatibility issues with Fmoc chemistry due to the nucleophilic piperidine used for deprotection [2] [3].

The **3,4-diaminobenzoic acid (Dbz) linker** and its derivative **MeDbz** (3-[(9-Fluorenylmethoxycarbonyl)amino]-4-(methylamino)benzoic acid) represent versatile platforms for NCL that overcome these limitations [2]. These linkers function as **crypto-thioesters**—stable during peptide synthesis but readily activated under specific conditions to generate the active thioester required for NCL. The Dbz approach offers exceptional flexibility by providing two distinct activation pathways: conversion to **N-acylbenzimidazolinone (Nbz)** or **benzotriazole (Bt)** derivatives, each with unique kinetic properties and

applications in protein synthesis [2]. This dual-pathway capability makes Dbz chemistry particularly valuable for complex synthetic targets requiring sequential ligations or those with challenging sequences.

The significance of Dbz-based methodologies extends to various applications in chemical biology and drug development, including the synthesis of **homogeneously modified proteins**, **cyclic peptides**, and **protein conjugates** for functional studies [4] [5] [3]. Moreover, the compatibility of Dbz chemistry with Fmoc-SPPS makes these advanced synthetic techniques accessible to a broader research community, as it eliminates the need for specialized Boc-SPPS equipment and hazardous HF handling [3].

Dbz Linker Mechanism and Comparative Approaches

Fundamental Chemical Principles

The Dbz linker enables peptide ligation through a **traceless mechanism** that ultimately yields a native peptide bond at the ligation site. The chemistry centers on an **o-aminoanilide intermediate** that can be selectively activated through different pathways to generate reactive species capable of undergoing thiol exchange and subsequent S-to-N acyl shift [2]. This activation occurs post-synthetically after complete assembly of the peptide chain, thus avoiding the instability issues associated with direct thioester incorporation during Fmoc-SPPS.

The **mechanistic pathway** begins with the Dbz-linked peptide, which features a free aromatic amine ortho to the peptide carbonyl. This strategic positioning allows for intramolecular cyclization upon activation, forming either an N-acylurea (Nbz) or benzotriazole (Bt) intermediate. These activated species are highly susceptible to **thiol-thioester exchange** when exposed to exogenous thiols (e.g., MPAA, thiophenol), generating the transient thioester that participates in the standard NCL mechanism with an N-terminal cysteine peptide [2]. The subsequent **intramolecular S-to-N acyl shift** proceeds through a favored 5-membered ring transition state, resulting in formation of the native peptide bond and release of the auxiliary group.

Comparative Analysis of Dbz Approaches

Table 1: Comparison of Dbz Activation Modalities for NCL

Feature	Nbz Pathway	Bt Pathway
Activation reagent	p-Nitrophenyl chloroformate	Sodium nitrite (NaNO ₂)
Activation pH	Basic (pH ~8-9)	Acidic (pH ~3-4)
Intermediate stability	Stable for characterization	Highly reactive
Ligation kinetics	Standard	Accelerated
Key advantage	Robustness for complex syntheses	Rapid transthioesterification (<5 minutes)
Compatibility	Broad with various sequences	Sensitive to oxidation-prone residues

The Dbz linker provides two complementary activation strategies with distinct characteristics. The **Nbz pathway** offers greater stability and control, making it suitable for complex multi-fragment assemblies where intermediate characterization is essential [2]. The Nbz derivative demonstrates good stability in aqueous solution, allowing for purification and characterization before the ligation step. This stability comes with moderately fast ligation kinetics, typically requiring several hours for completion under standard conditions.

In contrast, the **Bt pathway** provides significantly faster ligation kinetics due to the highly activated nature of the benzotriazole intermediate [2]. The Bt approach enables extremely rapid transthioesterification (often completing within 5 minutes), which can be advantageous for challenging ligations or acid-sensitive modifications. However, the high reactivity of the Bt intermediate limits opportunities for purification before ligation and may require immediate use after activation. The acidic activation conditions (pH 3-4) may also present compatibility issues with acid-labile modifications or sequences.

Experimental Protocols

Protocol 1: Nbz Activation and NCL via Dbz Linker

Principle: This protocol utilizes **p-nitrophenyl chloroformate activation** of the Dbz linker to form a stable N-acylurea (Nbz) intermediate, which undergoes efficient thiolysis to generate the peptide thioester in situ for NCL [2] [3].

Materials:

- Dbz-linked peptide (on resin or in solution)
- Anhydrous dimethylformamide (DMF) or N-methyl-2-pyrrolidone (NMP)
- p-Nitrophenyl chloroformate
- N,N-Diisopropylethylamine (DIEA)
- Dichloromethane (DCM)
- Trifluoroacetic acid (TFA) with appropriate scavengers (TIS, water)
- Ligation buffer: 6 M guanidine-HCl, 200 mM sodium phosphate, pH 7.2-7.5
- Thiol catalyst: 4-mercaptophenylacetic acid (MPAA, 200 mM) or mercaptoethanesulfonic acid (MESNA)
- Reducing agent: Tris(2-carboxyethyl)phosphine (TCEP, 50 mM)
- N-terminal cysteine peptide fragment

Procedure:

- **Resin-bound Activation (Recommended):**
 - Swell the Dbz-peptide-resin (100 μ mol) in anhydrous DCM (10 mL) for 30 minutes.
 - Prepare fresh activation solution: p-nitrophenyl chloroformate (5 equiv, 500 μ mol) in DCM (5 mL).
 - Add DIEA (10 equiv, 1 mmol) to the resin suspension, followed immediately by the activation solution.
 - React for 2 hours at room temperature with continuous agitation.
 - Wash sequentially with DCM, DMF, and methanol (3 \times 10 mL each).
 - Treat with DIEA (20 equiv, 2 mmol) in DMF (10 mL) for 1 hour to effect cyclization to the Nbz.
 - Wash thoroughly with DMF and DCM before cleavage.
- **Cleavage and Deprotection:**
 - Prepare cleavage cocktail: TFA/TIS/water (95:2.5:2.5, v/v/v, 10 mL).
 - Cleave the peptide from resin for 3 hours with agitation.
 - Filter to separate resin, concentrate filtrate under nitrogen stream.
 - Precipitate with cold diethyl ether, collect by centrifugation.
 - Dissolve in acetonitrile/water and lyophilize to obtain crude Nbz-peptide.
- **NCL Reaction:**

- Dissolve the Nbz-peptide (0.1 mmol) and cysteine-peptide (0.12 mmol) in ligation buffer (final concentration 2-5 mM).
- Add MPAA (200 mM final concentration) and TCEP (50 mM final concentration).
- Adjust to pH 7.2-7.5 if necessary, maintain under nitrogen atmosphere.
- Monitor reaction by analytical HPLC and LC-MS until completion (typically 4-24 hours).
- Purify ligated product by preparative RP-HPLC.

Critical Parameters:

- Peptide purity (>90%) before activation ensures efficient Nbz formation
- Maintain anhydrous conditions during chloroformate activation
- Use fresh DIEA to prevent decomposition of chloroformate
- Excess thiol catalyst (MPAA) drives complete thioester formation

Protocol 2: Bt Activation for Accelerated NCL

Principle: The **benzotriazole (Bt) approach** utilizes nitrosative activation of the Dbz linker to generate a highly reactive intermediate that enables ultrafast transthioesterification, significantly accelerating the NCL process [2].

Materials:

- Dbz-linked peptide
- Sodium nitrite (NaNO₂)
- 0.1 M HCl, pH 3.0 buffer
- Ligation buffer: 6 M guanidine-HCl, 200 mM sodium phosphate, pH 7.2
- MPAA (200 mM) or other aromatic thiols
- TCEP (50 mM)
- N-terminal cysteine peptide

Procedure:

- **Bt Formation:**
 - Dissolve Dbz-peptide (0.1 mmol) in pH 3.0 buffer (5 mL).
 - Cool solution to 0°C in ice bath.
 - Add sodium nitrite (10 equiv, 1 mmol) dissolved in cold water (1 mL).
 - React for 10 minutes at 0°C with monitoring by HPLC.
 - Quench reaction by adjusting to neutral pH with phosphate buffer.

- **Rapid NCL:**

- Immediately add the activated Bt-peptide solution to the cysteine-peptide (0.12 mmol) in ligation buffer.
- Include MPAA (200 mM) and TCEP (50 mM).
- React at room temperature, typically completing within 30-120 minutes.
- Monitor closely by LC-MS due to rapid kinetics.
- Purify product by preparative RP-HPLC.

Critical Parameters:

- Maintain low temperature during Bt formation to minimize side reactions
- Use immediate processing after Bt activation due to high reactivity
- Adjust thiol catalyst concentration based on peptide solubility
- Consider selenoesters for additional rate enhancement in challenging ligations [6]

Comparative Data and Optimization Guidelines

Performance Comparison of Dbz Methodologies

Table 2: Quantitative Comparison of Dbz and Related NCL Methods

Method	Typical Yield Range	Reaction Time	C-terminal Compatibility	Complexity
Dbz-Nbz	70-90%	4-24 hours	Broad (Gly, Ala, Val, Ile, Pro)	Moderate
Dbz-Bt	75-92%	0.5-4 hours	Broad, some sequence dependence	Low-Moderate
Direct Thioester	60-85%	12-48 hours	Limited by SPPS constraints	High (Boc-SPPS)
Peptide Hydrazide	65-88%	6-24 hours	Broad, except Asp/Gly at C-terminus	Moderate

Method	Typical Yield Range	Reaction Time	C-terminal Compatibility	Complexity
Convergent Hybrid Phase	80-95% (overall)	Varies by block	Optimal at less hindered residues	High

The Dbz methodologies consistently demonstrate **superior yields** and **reduced reaction times** compared to many conventional approaches, particularly for complex synthetic targets. The **convergent hybrid phase NCL (CHP-NCL)** strategy, which incorporates Dbz chemistry, has shown particular success with reported 2.5-fold yield improvements for challenging protein syntheses like CENP-A (139 residues) and efficient assembly of linker histone H1.2 (212 residues) from eight peptide segments [4]. This approach combines the advantages of solid-phase synthesis with the efficiency of solution-phase ligation, minimizing intermediate purification losses.

Amino Acid Compatibility and Kinetic Considerations

The Dbz linker demonstrates **broad compatibility** with all proteinogenic amino acids at the C-terminus, though ligation kinetics vary substantially based on steric and electronic factors [1] [6]. Glycine and alanine residues typically exhibit rapid ligation kinetics (complete within 2-6 hours), while **β-branched amino acids** (valine, isoleucine, threonine) and proline demonstrate significantly slower rates, often requiring 24-48 hours for complete conversion under standard conditions [1]. Recent mechanistic studies utilizing selenoester derivatives have revealed that for these challenging residues, the intramolecular S-to-N acyl shift becomes rate-limiting rather than the transthoesterification step [6].

For optimal results with hindered C-terminal residues, several **strategic modifications** are recommended:

- **Elevated MPAA concentrations** (up to 300 mM) to drive transthoesterification
- **Selenoester variants** providing 10-fold rate enhancement for problematic sequences [6]
- **Slight pH elevation** (pH 7.5-8.0) to enhance nucleophilicity while minimizing side reactions
- **Increased fragment concentrations** (5-10 mM) when solubility permits

Advanced Applications and Case Studies

Protein Total Synthesis: Linker Histone H1.2

The **convergent hybrid phase NCL (CHP-NCL)** strategy employing Dbz chemistry has enabled the efficient total synthesis of the 212-residue linker histone H1.2 from eight peptide segments with only a single final purification step [4]. This approach dramatically simplified the traditionally challenging synthesis of this chromatin-associated protein and permitted the preparation of homogeneously modified forms, including phosphorylated and citrullinated variants for functional studies.

The synthesis divided the target protein into two ~100-residue blocks, each assembled on solid support from four peptide fragments using Dbz chemistry, followed by a single solution-phase ligation of the two large segments. This strategy achieved an **overall yield increase of 2.5-fold** compared to previous approaches, primarily by minimizing intermediate purification losses. The successful application to H1.2 demonstrates the power of Dbz-based methodologies for accessing challenging protein targets, particularly those with **post-translational modifications** crucial for biological function.

Cyclic Peptide Synthesis: Kalata B1 and SFTI-1

Dbz chemistry has proven particularly valuable for the synthesis of **cyclic peptides** including the cyclotide kalata B1 and sunflower trypsin inhibitor-1 (SFTI-1) [3]. The protocol utilizes microwave-assisted Fmoc-SPPS with the Di-Fmoc-Dbz linker, enabling efficient on-resin Nbz formation followed by cleavage and in situ thioesterification for head-to-tail cyclization via NCL.

The key advantage of Dbz chemistry for cyclic peptide synthesis lies in its **compatibility with diverse C-terminal residues** including glycine, serine, arginine, and isoleucine, which are commonly encountered in naturally occurring cyclic peptides. This flexibility, combined with the avoidance of hazardous HF handling associated with Boc-SPPS, makes Dbz chemistry particularly attractive for producing cyclic peptide scaffolds for drug development and engineering applications.

Troubleshooting and Technical Considerations

Common Challenges and Solutions

- **Incomplete Nbz Formation:** Evidenced by poor conversion to thioester. Ensure fresh p-nitrophenyl chloroformate, anhydrous conditions, and sufficient DIEA concentration. Pre-activate the Dbz peptide with a small portion of resin before full-scale synthesis.
- **Slow Ligation Kinetics:** Particularly with β -branched amino acids. Implement selenoester variants [6] or increase thiol catalyst concentration (up to 300 mM MPAA). Consider elevated temperature (37°C) for difficult sequences.
- **Peptide Aggregation:** Utilize higher denaturant concentrations (6-8 M guanidine-HCl) or include chaotropes like urea. Incorporate solubility tags (e.g., Lys-rich sequences) for problematic fragments.
- **Dbz Overacylation:** Prevent by using MeDbz derivative or implementing orthogonal protection strategies when synthesizing Gly-rich sequences prone to this side reaction [2].

Strategic Planning for Multi-Fragment Assemblies

For complex multi-fragment syntheses, strategic **ligation site selection** is crucial. Prefer naturally occurring Cys residues or surface-exposed positions remote from functional sites when introducing non-native Cys residues [1]. The **convergent assembly** of protein blocks (100+ residues) using Dbz chemistry typically outperforms sequential approaches, as demonstrated by the successful synthesis of CENP-A and H1.2 [4]. When designing synthetic schemes, consider:

- **Fragment length limitations** (~50 residues for routine SPPS)
- **Compatibility with desulfurization** for converting Cys to Ala at non-native ligation sites
- **Strategic placement** of less reactive amino acids at internal rather than terminal ligation sites
- **Block size optimization** for hybrid phase approaches (typically 70-100 residues)

Visualized Workflows and Signaling Pathways

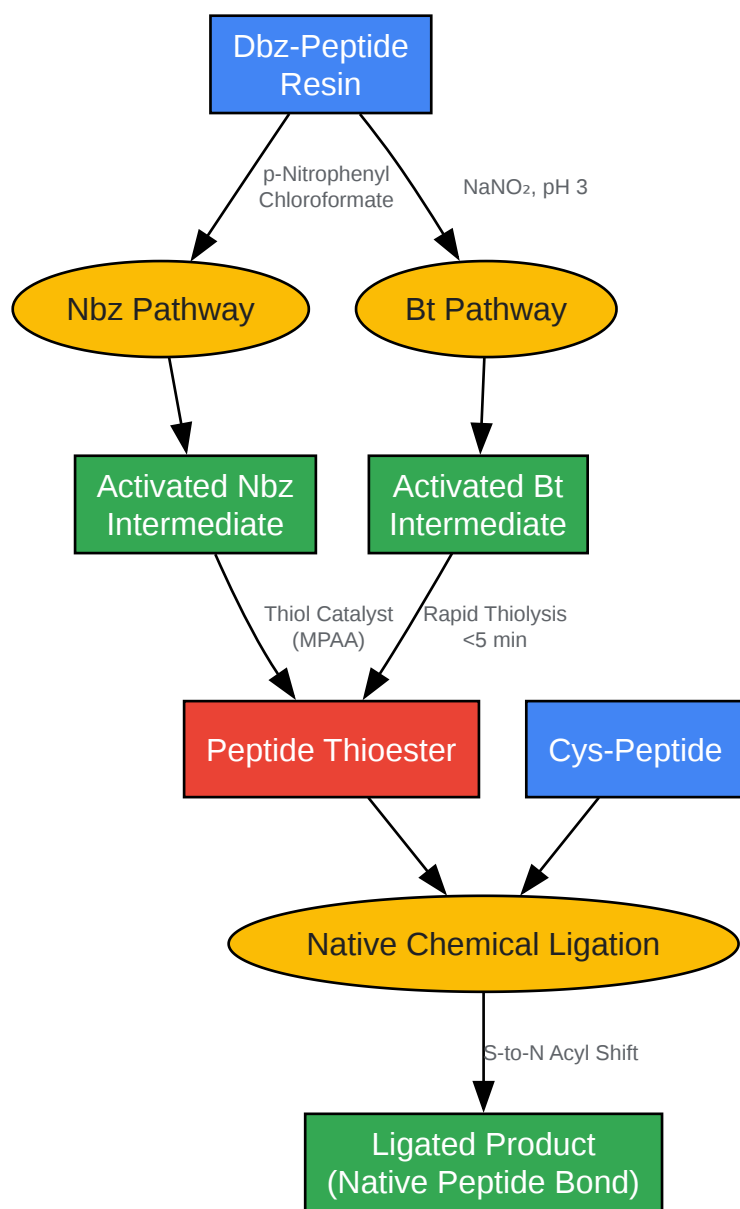

[Click to download full resolution via product page](#)

Diagram 1: Dbz Activation Pathways for Native Chemical Ligation. The Dbz linker offers two activation modalities—Nbz and Bt pathways—that converge to generate the active thioester for subsequent chemoselective reaction with an N-terminal cysteine peptide, ultimately forming a native peptide bond through S-to-N acyl shift [2].

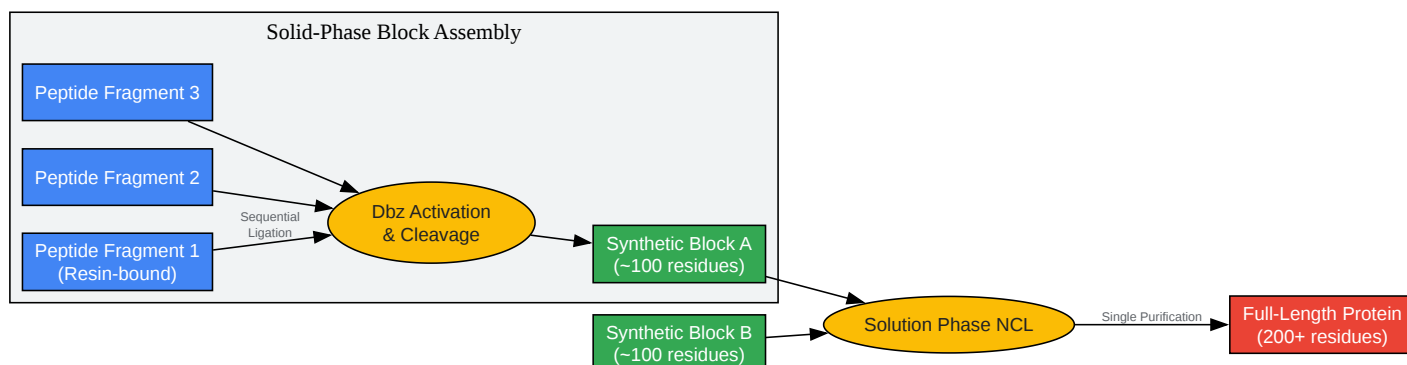

[Click to download full resolution via product page](#)

Diagram 2: Convergent Hybrid Phase NCL Strategy for Large Proteins. This approach utilizes Dbz chemistry to assemble large protein blocks (~100 residues) on solid support from smaller fragments, followed by a single solution-phase ligation and purification to generate full-length proteins exceeding 200 residues [4].

Conclusion

The **Dbz linker platform** represents a versatile and robust foundation for Native Chemical Ligation, particularly valuable for challenging synthetic targets requiring precise control over protein composition and modification. The **dual activation pathways** (Nbz and Bt) provide flexibility to optimize synthetic strategies based on sequence-specific constraints and kinetic requirements. When implemented within **convergent hybrid phase strategies**, Dbz chemistry enables efficient access to proteins exceeding 200 residues with complex modification patterns.

The continuing evolution of Dbz methodologies—including integration with **selenoester chemistry** for accelerated ligation and **advanced solid supports** for improved handling—promises to further expand the accessibility of chemical protein synthesis to the broader research community. These developments will

crucially support drug discovery efforts targeting **post-translationally modified proteins** and **complex protein-protein interactions** that remain challenging for conventional biological expression systems.

Need Custom Synthesis?

Email: info@smolecule.com or [Request Quote Online](#).

References

1. Native Chemical Ligation of Peptides and Proteins - PMC [[pmc.ncbi.nlm.nih.gov](https://pubmed.ncbi.nlm.nih.gov/)]
2. A versatile o-aminoanilide linker for native chemical ligation [[pmc.ncbi.nlm.nih.gov](https://pubmed.ncbi.nlm.nih.gov/)]
3. Making Ends Meet: Microwave-Accelerated Synthesis of Cyclic and... [link.springer.com]
4. Development of Convergent Hybrid Phase Ligation for ... [[pmc.ncbi.nlm.nih.gov](https://pubmed.ncbi.nlm.nih.gov/)]
5. Chemical approaches to explore ubiquitin-like proteins [pubs.rsc.org]
6. Kinetic and Mechanistic Studies of Native Chemical ... [[pmc.ncbi.nlm.nih.gov](https://pubmed.ncbi.nlm.nih.gov/)]

To cite this document: Smolecule. [Comprehensive Application Notes and Protocols for Native Chemical Ligation with Dbz Peptides]. Smolecule, [2026]. [Online PDF]. Available at:

[<https://www.smolecule.com/products/b6576694#native-chemical-ligation-ncl-with-dbz-peptides>]

Disclaimer & Data Validity:

The information provided in this document is for Research Use Only (RUO) and is strictly not intended for diagnostic or therapeutic procedures. While Smolecule strives to provide accurate protocols, we make no warranties, express or implied, regarding the fitness of this product for every specific experimental setup.

Technical Support: The protocols provided are for reference purposes. Unsure if this reagent suits your experiment? [Contact our Ph.D. Support Team for a compatibility check]

Need Industrial/Bulk Grade? [Request Custom Synthesis Quote](#)

Smolecule

Your Ultimate Destination for Small-Molecule (aka. smolecule) Compounds, Empowering Innovative Research Solutions Beyond Boundaries.

Contact

Address: Ontario, CA 91761, United States

Phone: (512) 262-9938

Email: info@smolecule.com

Web: www.smolecule.com