

Comprehensive Research Applications and Analytical Protocols for Xanthoanthrafil (Benzamidenafil)

Author: Smolecule Technical Support Team. Date: February 2026

Compound Focus: Xanthoanthrafil

CAS No.: 1020251-53-9

Cat. No.: S643147

[Get Quote](#)

Introduction to Xanthoanthrafil

Xanthoanthrafil (also known as benzamidenafil) is a synthetic **phosphodiesterase-5 (PDE5) inhibitor** with structural and functional similarities to pharmaceutical drugs such as sildenafil (Viagra) and tadalafil (Cialis). This compound first gained attention in the scientific literature when it was identified as an **undeclared adulterant** in dietary supplements marketed for sexual enhancement. [1] [2] Unlike approved pharmaceuticals, **xanthoanthrafil** has not undergone rigorous safety and efficacy testing, making it a significant concern for regulatory agencies and public health officials. The compound's chemical structure features a **benzamide core** with nitro, dimethoxybenzyl, and hydroxypropylamino substituents, contributing to its PDE5 binding affinity. [2]

Research interest in **xanthoanthrafil** primarily centers on its **detection and identification** in complex matrices, particularly adulterated dietary supplements. The presence of such undeclared pharmaceutical analogs in consumer products poses serious health risks, especially for individuals with pre-existing medical conditions who may be taking contraindicated medications such as nitrates. [3] This application note provides comprehensive information on **xanthoanthrafil's** chemical properties, analytical detection methods, and research applications to support scientists working in pharmaceutical analysis, regulatory science, and public health protection.

Chemical Properties and Structural Characteristics

Xanthoanthrafil possesses well-defined chemical characteristics that facilitate its identification and differentiation from other PDE5 inhibitors. The compound's systematic name is **N-[(3,4-dimethoxyphenyl)methyl]-2-[(1-hydroxypropan-2-yl)amino]-5-nitrobenzamide**, reflecting its complex molecular architecture. [2] The **presence of a chiral center** at the hydroxypropylamino side chain means the compound exists in different stereoisomeric forms, with the R-configuration exhibiting biological activity. [1]

Table 1: Fundamental Chemical Properties of **Xanthoanthrafil**

Property	Specification	Reference
CAS Number (unlabeled)	1020251-53-9	[4]
CAS Number (deuterated)	1216710-83-6	[5]
Molecular Formula	C ₁₉ H ₂₃ N ₃ O ₆	[1] [4]
Molecular Weight	389.40 g/mol	[4]
Deuterated Molecular Weight	392.42 g/mol	[5]
Deuterated Formula	C ₁₉ H ₂₀ D ₃ N ₃ O ₆	[5]
Specific Rotation	R-configuration (estimated by optical rotation)	[1]

The compound's structure includes several **functional groups** that influence its analytical behavior and biological activity: a **nitro group** essential for PDE5 binding, **methoxy groups** on the benzyl moiety, and a **hydroxy group** on the propylamino side chain. [1] [2] These features contribute to the compound's physicochemical properties, including its ionization characteristics, fragmentation pattern in mass spectrometry, and solubility profile. The deuterated version (**xanthoanthrafil-d3**) incorporates three deuterium atoms and serves as a valuable **internal standard** for quantitative analysis by NMR, GC-MS, or LC-MS, compensating for variability in sample preparation and instrument response. [5]

Analytical Detection Protocols

HPLC and LC-MS Screening Methods

High-performance liquid chromatography coupled with various detection systems has proven highly effective for identifying and quantifying **xanthoanthrafil** in complex matrices. The following protocol, adapted from published methodologies, provides reliable separation of **xanthoanthrafil** from other PDE5 inhibitors and matrix components: [3]

- **Equipment:** HPLC system with diode array detector (DAD) or mass spectrometer (MS); analytical balance; centrifugal filter units (0.45 μm); ultrasonic bath; micropipettes
- **Chromatographic Conditions:**
 - **Column:** Reversed-phase C18 column (e.g., Capcell PAK C18, 250 \times 4.6 mm, 5 μm)
 - **Mobile Phase:** Acetonitrile (A) and water containing 0.2% acetic acid (B)
 - **Gradient Elution:** Linear gradient from 20% A to 80% A over 15 minutes
 - **Flow Rate:** 0.2 mL/min
 - **Column Temperature:** 50°C
 - **Injection Volume:** 10 μL
 - **Detection:** DAD monitoring at 230 nm and 290 nm, or MS detection
- **Sample Preparation:**
 - **Homogenization:** Grind dietary supplement capsules or tablets to a fine powder using a mortar and pestle.
 - **Extraction:** Accurately weigh approximately 100 mg of sample into a 15 mL centrifuge tube. Add 10 mL of methanol and vortex vigorously for 1 minute.
 - **Sonication:** Sonicate the mixture for 15 minutes in an ultrasonic bath to facilitate complete extraction.
 - **Filtration:** Centrifuge at 4000 \times g for 5 minutes and pass the supernatant through a 0.45 μm syringe filter into an HPLC vial.
 - **Dilution:** If necessary, dilute the extract with methanol to bring the analyte concentration within the calibration range.
- **System Suitability:** Before analysis, verify system performance by injecting a standard solution containing 1 $\mu\text{g/mL}$ of **xanthoanthrafil**. The peak should be symmetric with a retention time of

approximately 12.5 minutes, and the relative standard deviation of retention times for consecutive injections should be less than 2%. [3]

Advanced LC-MS/MS Configuration

For confirmatory analysis, **liquid chromatography coupled with ion trap-time of flight mass spectrometry (LC-IT-TOF-MS)** provides high-resolution accurate mass measurements and structural information through multistage fragmentation:

- **MS Parameters:**
 - **Ionization Mode:** Electrospray ionization (ESI) in positive mode
 - **Nebulizing Gas:** Nitrogen at 1.5 L/min
 - **Drying Gas:** Nitrogen at 200 kPa
 - **Heat Block Temperature:** 200°C
 - **Interface Temperature:** 250°C
 - **Detector Voltage:** 1.65 kV
 - **Mass Range:** m/z 100-1000
- **Data Acquisition:**
 - **Full Scan MS:** Resolution >10,000 FWHM
 - **Auto MS/MS:** Data-dependent acquisition selecting the top 3 most intense ions
 - **Collision Energy:** 50% with argon as collision gas
 - **Isolation Width:** 3.0 m/z

This configuration enables the identification of **xanthoanthrafil** based on both **retention time matching** (approximately 12.5 minutes) and **accurate mass measurement** of the protonated molecule ($[M+H]^+$ m/z 390.1660) and characteristic fragment ions. [3] The typical mass error should be less than 5 ppm when compared with theoretical values, ensuring high confidence in compound identification.

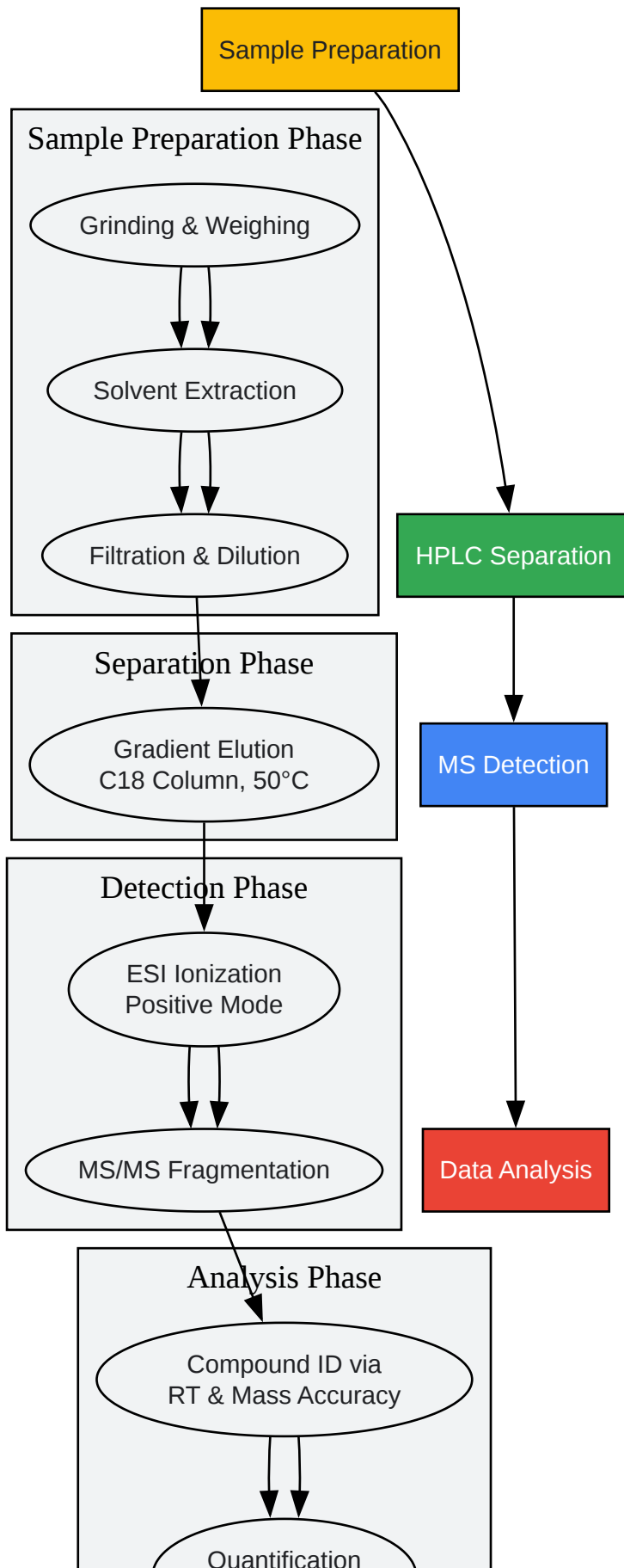

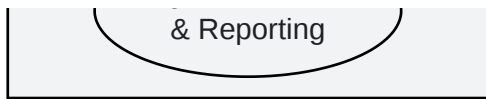

Click to download full resolution via product page

Figure 1: Analytical Workflow for **Xanthoanthrafil** Detection. The process encompasses sample preparation, chromatographic separation, mass spectrometric detection, and data analysis phases.

Research Applications and Experimental Data

Quantitative Analysis in Dietary Supplements

Research applications for **xanthoanthrafil** primarily focus on its **detection and quantification** in adulterated products. In one foundational study, researchers identified **xanthoanthrafil** in a dietary supplement promoted for sexual enhancement at a concentration of approximately **31 mg per capsule**. [1] This quantitative analysis employed a validated HPLC method with confirmation by NMR spectroscopy, establishing the compound's presence as an undeclared pharmaceutical ingredient.

Table 2: Experimental Data on **Xanthoanthrafil** Potency and Adulteration

Research Context	Quantitative Finding	Methodology	Reference
PDE5 Inhibitory Potency	IC ₅₀ = 3.95 ng/mL	Enzymatic assay	[5]
Product Adulteration	31 mg/capsule	HPLC with quantitative NMR	[1]
Chromatographic Retention	12.5 minutes	LC-IT-TOF MS, C18 column, 0.2% acetic acid/acetonitrile gradient	[3]

The **potency of xanthoanthrafil** as a PDE5 inhibitor has been quantitatively established through enzymatic assays, demonstrating an IC₅₀ value of 3.95 ng/mL. [5] This indicates strong inhibitory activity against the phosphodiesterase-5 enzyme, which explains its physiological effects and its selection as an adulterant in

products marketed for erectile dysfunction. The IC_{50} value places **xanthoanthrafil** among the more potent PDE5 inhibitors, though direct comparisons with approved pharmaceuticals require careful interpretation due to potential differences in experimental conditions.

Pharmacological Mechanism and Signaling Pathway

Xanthoanthrafil exerts its physiological effects through **specific inhibition** of phosphodiesterase-5 (PDE5), the primary enzyme responsible for hydrolyzing cyclic guanosine monophosphate (cGMP) in vascular smooth muscle cells. Under normal physiological conditions, sexual stimulation triggers the release of nitric oxide (NO) from nerve endings and endothelial cells in the corpus cavernosum of the penis. This NO diffuses into smooth muscle cells and activates the enzyme guanylyl cyclase, which converts GTP to cGMP. The resulting increased cGMP levels promote smooth muscle relaxation through protein kinase G-mediated phosphorylation, allowing increased blood flow and consequent erection. [3]

PDE5 normally terminates this signaling cascade by hydrolyzing cGMP to 5'-GMP. **Xanthoanthrafil** **competitively inhibits** this hydrolysis by binding to the catalytic site of PDE5, which is composed of 16 helices and 16 loops at the C-terminal end (amino acid residues 535-860) of the enzyme. [3] This binding results in elevated intracellular cGMP levels, enhancing and prolonging the natural erection process. The molecular structure of **xanthoanthrafil**, particularly its nitro group and benzamide core, facilitates specific interactions with the PDE5 active site, mimicking the natural substrate cGMP while resisting hydrolysis.

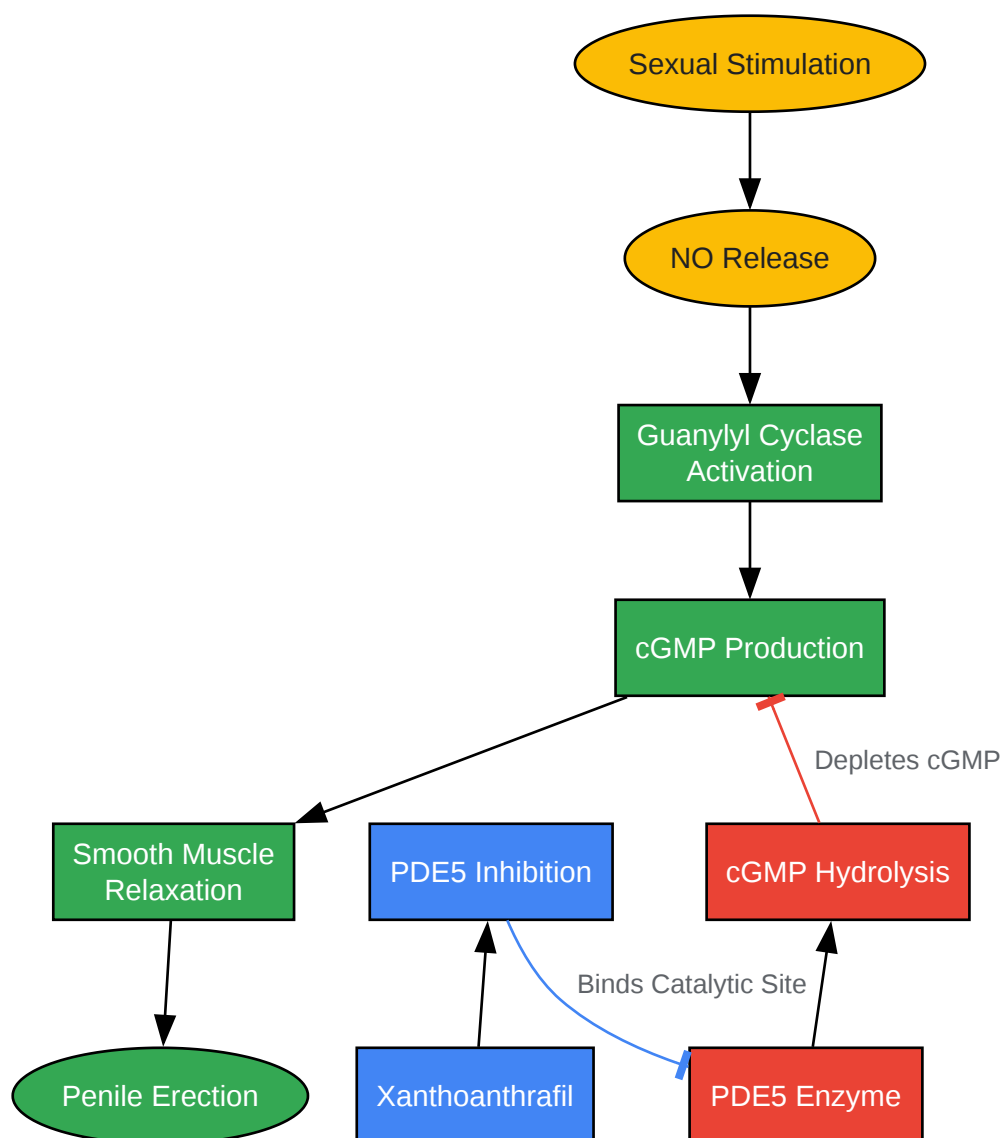

[Click to download full resolution via product page](#)

*Figure 2: Pharmacological Mechanism of **Xanthoantrafil**. The diagram illustrates how **xanthoantrafil** inhibits PDE5 to prevent cGMP hydrolysis, thereby enhancing the natural erection pathway.*

Safety and Regulatory Considerations

Xanthoantrafil poses significant safety concerns due to its presence as an undeclared adulterant in dietary supplements and the potential for serious adverse interactions with other medications. The compound has been found in products marketed as "natural" sexual enhancement supplements, often without

appropriate labeling or dosage information. [2] This deceptive practice is particularly dangerous because consumers may unknowingly ingest pharmaceutical ingredients that could interact with other medications.

- **Cardiovascular Risks:** Like other PDE5 inhibitors, **xanthoanthrafil** can cause significant drops in blood pressure, especially when taken with nitrates (commonly prescribed for angina). This interaction can lead to **potentially fatal hypotension**. [3]
- **Quality Control Issues:** Adulterated products containing **xanthoanthrafil** typically lack manufacturing quality control, resulting in **inconsistent dosing**. One study found approximately 31 mg per capsule, but potency may vary considerably between products and even between batches of the same product. [1]
- **Regulatory Status:** **Xanthoanthrafil** is **not approved** by any regulatory agency for medicinal use. Its presence in dietary supplements constitutes adulteration and violates regulations in most countries. The FDA has issued warnings about similar unapproved PDE5 inhibitors in supplements. [2]

Researchers should exercise appropriate precautions when handling **xanthoanthrafil** reference standards, using personal protective equipment and working in properly ventilated environments. All analytical methods should include adequate quality control measures, such as matrix blanks, calibration standards, and reference materials, to ensure accurate identification and quantification.

Conclusion

Xanthoanthrafil represents a case study of **pharmaceutical adulteration** in the dietary supplement market, highlighting the importance of robust analytical methods for detecting undeclared synthetic compounds in consumer products. The analytical protocols described in this application note, particularly HPLC-DAD and LC-IT-TOF-MS methods, provide reliable approaches for identifying and quantifying this PDE5 inhibitor in complex matrices. These methods support research applications in regulatory science, public health protection, and pharmaceutical analysis.

Future research directions may include the development of **high-throughput screening methods** for **xanthoanthrafil** and related PDE5 inhibitors, studies on the metabolism and pharmacokinetics of this compound, and investigations into its potential interactions with other medications. As the landscape of product adulteration continues to evolve with the emergence of new structural analogs, the analytical

techniques and fundamental knowledge presented here provide a foundation for ongoing research efforts to protect consumers from potentially dangerous undeclared pharmaceuticals in dietary supplements.

Need Custom Synthesis?

Email: info@smolecule.com or [Request Quote Online](#).

References

1. Determination of (*R*)- Xanthoantrafil ... [jstage.jst.go.jp]
2. Benzamidenafil - Wikipedia [en.wikipedia.org]
3. Screening of Phosphodiesterase-5 Inhibitors and Their ... [pmc.ncbi.nlm.nih.gov]
4. rac Xanthoantrafil | CAS 1020251-53-9 | SCBT - Santa Cruz... [scbt.com]
5. Xanthoantrafil-d3 | Stable Isotope [medchemexpress.com]

To cite this document: Smolecule. [Comprehensive Research Applications and Analytical Protocols for Xanthoantrafil (Benzamidenafil)]. Smolecule, [2026]. [Online PDF]. Available at:

[<https://www.smolecule.com/products/b643147#xanthoantrafil-research-applications>]

Disclaimer & Data Validity:

The information provided in this document is for Research Use Only (RUO) and is strictly not intended for diagnostic or therapeutic procedures. While Smolecule strives to provide accurate protocols, we make no warranties, express or implied, regarding the fitness of this product for every specific experimental setup.

Technical Support: The protocols provided are for reference purposes. Unsure if this reagent suits your experiment? [Contact our Ph.D. Support Team for a compatibility check]

Need Industrial/Bulk Grade? Request Custom Synthesis Quote

Smolecule

Your Ultimate Destination for Small-Molecule (aka. smolecule) Compounds, Empowering Innovative Research Solutions Beyond Boundaries.

Contact

Address: Ontario, CA 91761, United States

Phone: (512) 262-9938

Email: info@smolecule.com

Web: www.smolecule.com