

Orysastrobin strobilurin fungicide properties

Author: Smolecule Technical Support Team. Date: February 2026

Compound Focus: Orysastrobin

CAS No.: 248593-16-0

Cat. No.: S636842

Get Quote

Orysastrobin Basic Properties

The table below summarizes the key identification and physical property data available for **orysastrobin**.

Property Category	Details
IUPAC Name	A monocarboxylic acid amide obtained by formal condensation of the carboxy group of (2E)-(methoxyimino){2-[(3E,5E,6E)-5-(methoxyimino)-4,6-dimethyl-2,8-dioxa-3,7-diazanona-3,6-dien-1-yl]phenyl}acetic acid with the amino group of methylamine [1]
CAS Registry Number	248593-16-0 [1]
Molecular Formula	C ₁₈ H ₂₅ N ₅ O ₅ [1]
Molecular Weight	391.43 g/mol [1]
Melting Point	97–101 °C [1]
Predicted Density	1.16 ± 0.1 g/cm ³ [1]

Property Category	Details
Solubility	Slightly soluble in DMSO and Methanol [1]
pKa	11.26 ± 0.46 (Predicted) [1]
Appearance	White to off-white solid [1]

Strobilurin Class Context and Mechanism of Action

As a strobilurin fungicide, **orysastrobin** shares a common biochemical mode of action with other compounds in this class, such as azoxystrobin. The following diagram illustrates this mechanism.

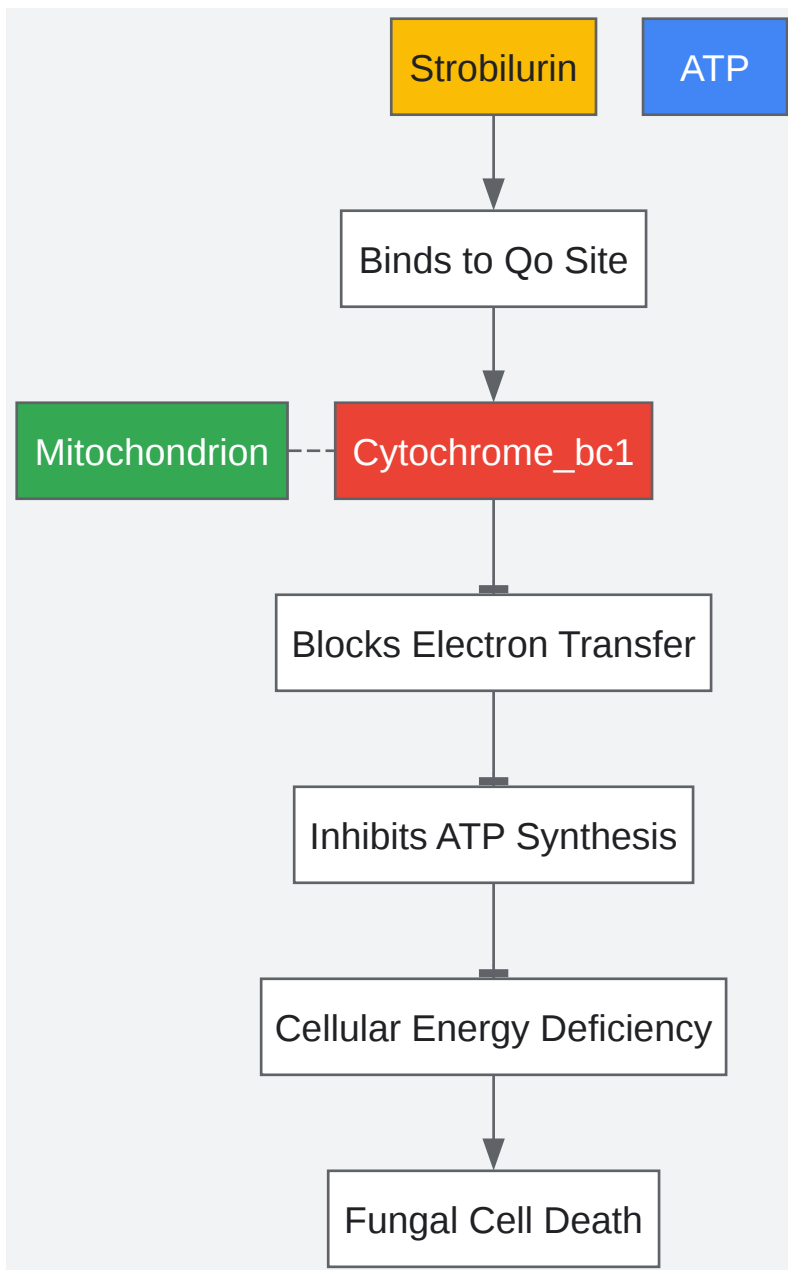

[Click to download full resolution via product page](#)

Strobilurin inhibition of mitochondrial respiration leading to fungal cell death.

This mechanism is supported by studies on azoxystrobin, which show it binds to the **quinol outer (Qo) site** of the cytochrome bc1 complex, inhibiting mitochondrial respiration and energy production [2] [3] [4].

Market and Resistance Landscape

Oryastrobin is specialized for controlling blast and sheath blight in transplanted rice, targeting pathogens like *Magnaporthe oryzae* and *Rhizoctonia solani* [1]. The strobilurin market is growing, valued at USD 4.6 billion in 2024 and projected to reach USD 6.3 billion by 2033 [5].

A major challenge is **fungal resistance**, often linked to the G143A mutation in the cytochrome b gene [6]. This has led to increased development of pre-mixed formulations with fungicides from other classes to provide multi-site action and prolong effectiveness [6] [5].

Experimental and Safety Considerations

For researchers designing experiments, note that strobilurins as a class can pose risks to non-target organisms, particularly aquatic life [4]. Standard ecotoxicity testing and careful disposal are essential.

While specific metabolic pathways for **oryastrobin** are not detailed in the search results, its degradation in the environment is likely influenced by abiotic factors like photolysis and pH, similar to other strobilurins [3].

Information Availability and Next Steps

The technical data on **oryastrobin** in the public domain is limited. The information presented relies heavily on a single chemical supplier profile [1] and inferences from the well-documented strobilurin azoxystrobin [2] [7] [4].

To proceed with your whitepaper, I suggest you:

- **Consult specialized databases** such as the Pesticide Properties DataBase (PPDB) for more complete environmental fate and toxicity data.
- **Search patent literature** for original synthesis routes and biological efficacy data.
- **Access primary research articles** through scientific journals for detailed experimental protocols and residue analysis methods.

Need Custom Synthesis?

Email: info@smolecule.com or Request Quote Online.

References

1. Orysastrobin CAS#: 248593-16-0 [chemicalbook.com]
2. Azoxystrobin [en.wikipedia.org]
3. An Overview of Strobilurin Fungicide Degradation:Current ... [pmc.ncbi.nlm.nih.gov]
4. Azoxystrobin - an overview | ScienceDirect Topics [sciencedirect.com]
5. Strobilurin Fungicide Market Size & Growth [2033] [marketreportsworld.com]
6. Strobilurin Market Size, Share, Growth, and Forecast - 2030 [marketsandmarkets.com]
7. Azoxystrobin (Ref: ICI 5504) - AERU - University of Hertfordshire [sitem.herts.ac.uk]

To cite this document: Smolecule. [Orysastrobin strobilurin fungicide properties]. Smolecule, [2026]. [Online PDF]. Available at: [<https://www.smolecule.com/products/b636842#orysastrobin-strobilurin-fungicide-properties>]

Disclaimer & Data Validity:

The information provided in this document is for Research Use Only (RUO) and is strictly not intended for diagnostic or therapeutic procedures. While Smolecule strives to provide accurate protocols, we make no warranties, express or implied, regarding the fitness of this product for every specific experimental setup.

Technical Support: The protocols provided are for reference purposes. Unsure if this reagent suits your experiment? [Contact our Ph.D. Support Team for a compatibility check]

Need Industrial/Bulk Grade? Request Custom Synthesis Quote

Smolecule

Your Ultimate Destination for Small-Molecule (aka. smolecule) Compounds, Empowering Innovative Research Solutions Beyond Boundaries.

Contact

Address: Ontario, CA 91761, United States

Phone: (512) 262-9938

Email: info@smolecule.com

Web: www.smolecule.com