

Established Workflow for Evaluating Compounds in Patient-Derived Models

Author: Smolecule Technical Support Team. **Date:** February 2026

Compound Focus: Avocadyne

CAS No.: 24607-05-4

Cat. No.: S614010

[Get Quote](#)

The field of functional precision medicine often uses a workflow that moves from a patient's tumor to an **ex vivo** drug sensitivity test. The diagram below illustrates this general process, which is agnostic to the specific compound being tested [1].



[Click to download full resolution via product page](#)

The key technological platforms and their roles in this workflow are summarized in the table below.

Technology / Platform	Role in Efficacy Testing	Key Features & Requirements
Patient-Derived Organoids (PDOs) [1]	Serve as ex vivo avatars of a patient's tumor for direct drug testing.	Retain genetic and histological features of the original tumor; self-renewing; suitable for high-throughput screening.
High-Content Screening (HCS) [2]	Uses automated microscopy & image analysis to quantify effects of compounds on cell functions.	Allows multiplexed analysis of complex cell functions (e.g., cell death, morphology) in multi-well plates.

Technology / Platform	Role in Efficacy Testing	Key Features & Requirements
High-Throughput Screening (HTS) [2]	Enables rapid testing of a compound against a large panel of drugs or across many PDO lines.	Robotic automation; uses 384- or 1,536-well plates; requires robust and scalable cell culture methods.

Molecular Mechanisms and Signaling Pathways

In the absence of data on **Avocadyne**, understanding general mechanisms of drug action and signaling pathways is crucial for designing experiments. The following diagram illustrates a generalized signaling cascade that is often investigated in cancer and other diseases [3] [4].

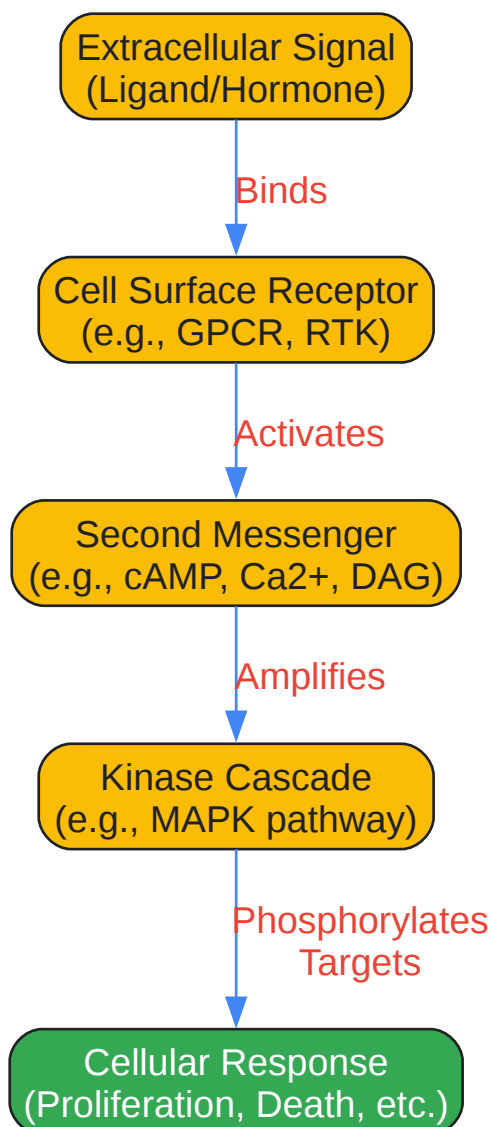

[Click to download full resolution via product page](#)

Key components of drug action and signaling that should be characterized for any new compound include [3] [4]:

- **Agonist vs. Antagonist Activity:** Determining if the compound activates (agonist) or blocks (antagonist) a receptor pathway.
- **Signaling Pathways:** Identifying which specific pathways (e.g., MAPK, PI3K) are modulated by the compound.
- **Cellular Response:** Measuring the ultimate biological outcome, such as cytotoxicity, growth inhibition, or differentiation.

How to Proceed with Research on Avocadyne

Since no direct data exists, here are steps you can take to build a research plan:

- **Check Broader Literature:** Investigate if **Avocadyne** has been studied in conventional cell lines or animal models, which can provide clues about its potential mechanisms and efficacy.
- **Design Original Experiments:** You could propose a study to test **Avocadyne** yourself using the PDO and HCS methodologies described above.
- **Explore Related Compounds:** Research the efficacy of structurally or functionally similar compounds in patient-derived models. This can help form a hypothesis about **Avocadyne**'s potential.

Need Custom Synthesis?

Email: info@smolecule.com or [Request Quote Online](#).

References

1. Implementing patient organoids in functional precision... derived [jccr.biomedcentral.com]
2. Frontiers | Patient - derived stem cells : pathways to drug discovery for... [frontiersin.org]
3. of Molecular transduction mechanisms of drug... signaling pathways [bjbas.springeropen.com]
4. Cell Signaling : Types and Mechanisms | DanaHER Life Sciences [lifesciences.danaHER.com]

To cite this document: Smolecule. [Established Workflow for Evaluating Compounds in Patient-Derived Models]. Smolecule, [2026]. [Online PDF]. Available at:

[<https://www.smolecule.com/products/b614010#avocadyne-efficacy-in-patient-derived-cells>]

Disclaimer & Data Validity:

The information provided in this document is for Research Use Only (RUO) and is strictly not intended for diagnostic or therapeutic procedures. While Smolecule strives to provide accurate protocols, we make no warranties, express or implied, regarding the fitness of this product for every specific experimental setup.

Technical Support: The protocols provided are for reference purposes. Unsure if this reagent suits your experiment? [Contact our Ph.D. Support Team for a compatibility check]

Need Industrial/Bulk Grade? Request Custom Synthesis Quote

Smolecule

Your Ultimate Destination for Small-Molecule (aka. smolecule) Compounds, Empowering Innovative Research Solutions Beyond Boundaries.

Contact

Address: Ontario, CA 91761, United States

Phone: (512) 262-9938

Email: info@smolecule.com

Web: www.smolecule.com