

# articaine pharmacodynamics protein binding liposolubility

**Author:** Smolecule Technical Support Team. **Date:** February 2026

## Compound Focus: Articaine

CAS No.: 23964-58-1

Cat. No.: S603454

Get Quote

## Core Pharmacodynamic Properties of Articaine

The table below summarizes the key pharmacodynamic properties of **articaine** that determine its clinical behavior [1].

Property	Description & Clinical Significance
<b>Chemical Class</b>	Amide local anesthetic with a unique <b>thiophene ring</b> (increases liposolubility) and an ester group (enables rapid hydrolysis) [2] [1].
<b>Mechanism of Action</b>	Reversibly binds to the $\alpha$ -subunit of voltage-gated sodium channels from the inner cavity of the nerve. This inhibits sodium influx, prevents depolarization, and halts nerve impulse conduction [3] [1].
<b>Liposolubility</b>	High. The thiophene ring enhances its ability to diffuse through lipid-rich nerve membranes, contributing to a faster onset and improved tissue diffusion [2] [1].
<b>Protein Binding</b>	Approximately <b>94%</b> (primarily to plasma proteins). High protein binding correlates with a longer duration of action, as less free drug is available for metabolism [1].

Property	Description & Clinical Significance
Relative Potency	Considered intermediate-potency. A 4% formulation is used to achieve effectiveness comparable to 2% lidocaine, providing greater overall effectiveness for the dentition [2] [1].
Onset of Action	Rapid; typically <b>1 to 2 minutes</b> in infiltration injections, making it one of the fastest-acting dental local anesthetics [2].

## Experimental Protocols for Pharmacodynamic Study

For researchers investigating **articaine**'s mechanisms, here are methodologies from published studies.

### Molecular Dynamics (MD) Simulation of **Articaine-Lipid Bilayer Interaction**

This protocol uses computational modeling to study how **articaine** penetrates and interacts with cell membranes at the atomic level [4].

- **System Setup:**
  - **Membrane Model:** Construct a bilayer of dimyristoylphosphatidylcholine (DMPC) lipids, hydrated with water molecules.
  - **Articaine Molecules:** Place **articaine** molecules in both neutral and charged forms in the aqueous phase.
  - **Software:** Simulations are performed using GROMACS software.
- **Simulation & Analysis:**
  - **Equilibration:** Run an initial simulation to stabilize the system.
  - **Umbrella Sampling:** Apply this technique to calculate the Potential of Mean Force (PMF). The PMF reveals the free energy profile and identifies the most energetically favorable locations (binding sites) for **articaine** within the lipid bilayer.
  - **Parameters Measured:** Analyze the diffusion coefficient of **articaine**, the electrostatic potential across the membrane, and changes in the lipid bilayer's order parameter to understand membrane disruption.
- **Application:** This method helps explain **articaine**'s high diffusibility and how its lipophilicity facilitates passage through the neural sheath [2] [4].

## In Vivo Assessment of Anesthetic Efficacy in Pulpitis

This clinical model evaluates the relative effectiveness of different anesthetics in a pathologically inflamed tissue, which is a common clinical challenge [2].

- **Subject Selection:** Identify patients with a diagnosis of symptomatic irreversible pulpitis in a mandibular tooth.
- **Intervention:** Administer an inferior alveolar nerve block using a standard volume (e.g., 1.8 mL) of the local anesthetic under investigation (e.g., 4% **articaine** with epinephrine).
- **Outcome Measurement:**
  - **Primary Outcome:** "Success" is defined as the ability to access and instrument the pulp chamber without significant pain.
  - **Data Analysis:** Compare success rates between **articaine** and other local anesthetics (e.g., lidocaine, mepivacaine) using meta-analysis of multiple randomized controlled trials.
- **Key Finding:** This methodology has demonstrated that **articaine** has a significantly higher success rate (approx. 70%) in anesthetizing teeth with irreversible pulpitis compared to lidocaine (approx. 52%) [2].

## Mechanism of Action Signaling Pathway

The following diagram illustrates the pathway through which **articaine** exerts its anesthetic effect at the molecular and physiological levels.

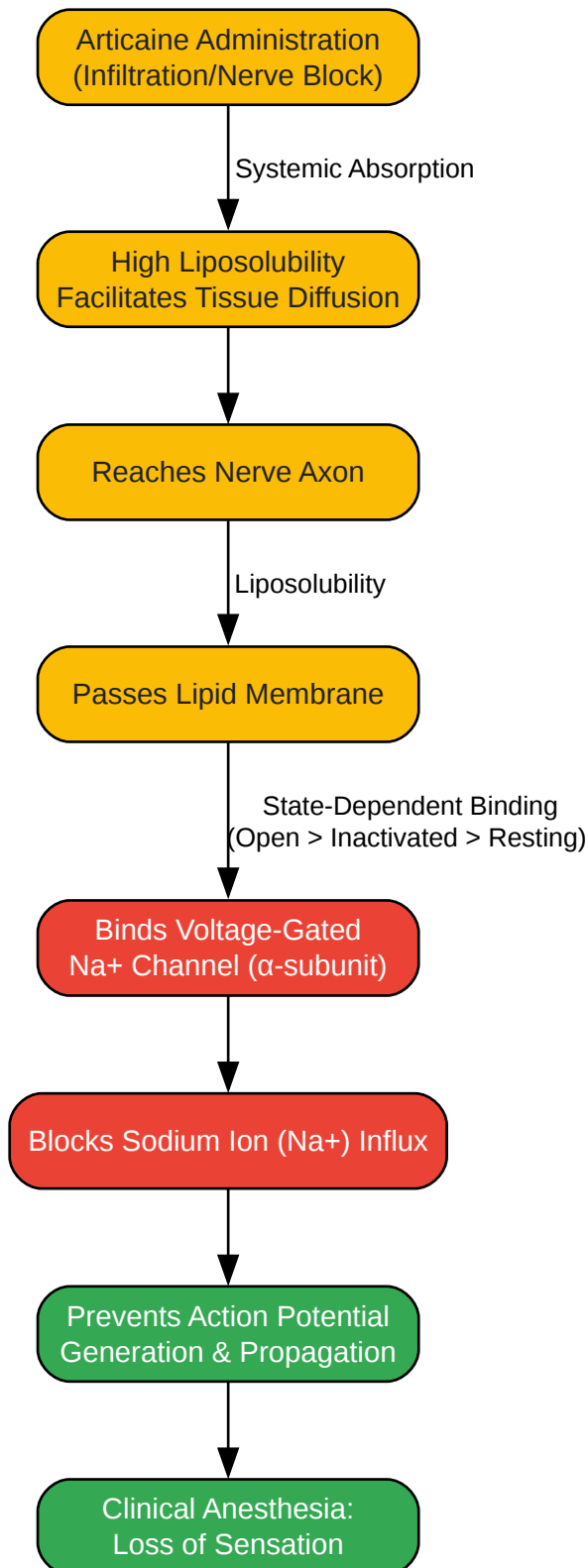

[Click to download full resolution via product page](#)

*Articaïne's pathway from administration to nerve signal blockade.*

## Correlation of Properties and Clinical Performance

The pharmacodynamic properties of **articaine** directly translate into its clinical advantages [2]:

- **Enhanced Diffusibility:** Due to its high liposolubility, a buccal infiltration of **articaine** can often anesthetize palatal and lingual tissues without the need for separate, more painful injections [2].
- **Efficacy in Pulpitis:** **Articaine's** superior success rate in cases of irreversible pulpitis, particularly in mandibular teeth via nerve block, is attributed to its enhanced ability to diffuse through inflamed and densely organized tissues [2].
- **Rapid Metabolism and Safety:** Despite being a 4% concentration, **articaine** has a short plasma half-life (approximately 20-45 minutes in healthy individuals) because it is rapidly hydrolyzed by plasma esterases. This rapid metabolism reduces the risk of systemic toxicity [2] [1].

### Need Custom Synthesis?

Email: [info@smolecule.com](mailto:info@smolecule.com) or Request Quote Online.

## References

1. : a review of its use for local and regional anesthesia - PMC Articaine [pmc.ncbi.nlm.nih.gov]
2. Current Perspectives on Articaine in Dental... - Decisions in Dentistry [decisionsindentistry.com]
3. : Uses, Interactions, Mechanism of Action | DrugBank Online Articaine [go.drugbank.com]
4. Effects of protein on a lipid bilayer containing local anesthetic... binding [link.springer.com]

To cite this document: Smolecule. [articaine pharmacodynamics protein binding liposolubility].

Smolecule, [2026]. [Online PDF]. Available at:

[<https://www.smolecule.com/products/b603454#articaine-pharmacodynamics-protein-binding-liposolubility>]

### Disclaimer & Data Validity:

The information provided in this document is for Research Use Only (RUO) and is strictly not intended for diagnostic or therapeutic procedures. While Smolecule strives to provide accurate protocols, we make no

warranties, express or implied, regarding the fitness of this product for every specific experimental setup.

**Technical Support:** The protocols provided are for reference purposes. Unsure if this reagent suits your experiment? [Contact our Ph.D. Support Team for a compatibility check]

**Need Industrial/Bulk Grade?** Request Custom Synthesis Quote

## Smolecule

Your Ultimate Destination for Small-Molecule (aka. smolecule) Compounds, Empowering Innovative Research Solutions Beyond Boundaries.

### Contact

**Address:** Ontario, CA 91761, United States

**Phone:** (512) 262-9938

**Email:** [info@smolecule.com](mailto:info@smolecule.com)

**Web:** [www.smolecule.com](http://www.smolecule.com)