

# Comprehensive Application Notes and Protocols: Industrial Ethylene Production via Steam Cracking

**Author:** Smolecule Technical Support Team. **Date:** February 2026

**Compound Focus:** Ethene; ethenyl acetate

CAS No.: 104912-80-3

Cat. No.: S595908

Get Quote

## Introduction to Steam Cracking and Ethylene Production

Ethylene ( $C_2H_4$ ) represents one of the most fundamental **building blocks** of the global petrochemical industry, serving as the primary precursor for countless downstream products including polyethylene plastics, ethylene oxide, ethylene dichloride, and various other essential chemicals [1]. The **industrial significance** of ethylene stems from its molecular structure—a simple hydrocarbon with a highly reactive double bond that enables diverse transformation pathways into valuable materials [2]. Global ethylene production has expanded dramatically from approximately 1.5 million metric tons annually in the mid-1950s to current levels exceeding 225 million metric tons per year, with single facility capacities growing from 70,000 to over 2 million tons annually during the same period [2]. This **exponential growth** underscores ethylene's critical role in supporting modern infrastructure across packaging, automotive, textiles, construction, and healthcare sectors.

The **dominant production method** for ethylene is steam cracking, accounting for the vast majority of global production capacity [1] [2]. Steam cracking involves the thermal decomposition of hydrocarbon feedstocks at elevated temperatures (750–900°C) in the presence of steam, which acts as a diluent to suppress unwanted side reactions [1]. The process operates through a **free radical mechanism** that breaks larger hydrocarbon

molecules into smaller, more valuable olefins [2]. Despite decades of optimization, steam cracking remains one of the most **energy-intensive processes** in the chemical industry, consuming approximately 16-23 GJ per ton of ethylene produced depending on feedstock, while simultaneously generating significant greenhouse gas emissions [3]. As global sustainability imperatives intensify, the ethylene industry faces mounting pressure to develop and implement **decarbonization strategies** while maintaining economic competitiveness in an increasingly challenging market environment [1] [4].

## Process Chemistry and Reaction Mechanisms

### Free Radical Reaction Pathway

The steam cracking process follows a well-established **free radical mechanism** comprising three fundamental steps: initiation, propagation, and termination. In the **initiation phase**, high temperatures (750–900°C) break carbon-carbon bonds in hydrocarbon feedstocks, generating highly reactive free radicals with unpaired electrons [2]. For ethane cracking, this initiation occurs as:  $C_2H_6 \rightarrow C_2H_5\cdot + H\cdot$ . These unstable radicals then undergo **propagation reactions**, where they decompose, isomerize, or abstract hydrogen atoms to form olefinic products [2]. A key propagation step in ethane cracking involves the decomposition of ethyl radical:  $C_2H_5\cdot \rightarrow C_2H_4 + H\cdot$ . Finally, the **termination phase** occurs when radicals combine to form stable products, such as:  $2C_2H_5\cdot \rightarrow nC_4H_{10}$  [2].

The **reaction network** becomes significantly more complex with heavier feedstocks like naphtha or propane, involving numerous parallel and consecutive reactions. **Secondary reactions** play a crucial role in determining final product distribution, with olefins and dienes undergoing cyclization to form aromatic compounds like benzene, toluene, and xylenes (BTX) [2]. Further dehydrogenation reactions can produce **polycyclic aromatic hydrocarbons (PAHs)** such as naphthalene and anthracene, which ultimately undergo polymerization and dehydrogenation to form coke deposits on reactor walls [2]. The formation of these **carbonaceous deposits** represents a major operational challenge, gradually reducing heat transfer efficiency and increasing pressure drop until decoking operations become necessary [2].

### Key Operational Parameters and Their Impact

- **Temperature and Severity:** The **coil outlet temperature** (COT) directly determines cracking severity, which measures feed conversion [2]. Higher temperatures increase ethylene yields but also accelerate coke formation and energy consumption [2]. Optimal temperature ranges typically span 800–850°C for ethane cracking and 750–800°C for naphtha feeds, representing a balance between maximizing ethylene production and minimizing undesirable side reactions [1].
- **Residence Time:** Modern steam crackers operate with **short residence times** (0.1–0.5 seconds) to maximize ethylene selectivity by limiting secondary reactions that form heavier byproducts [2]. Longer residence times favor recombination reactions that reduce ethylene yield while increasing acetylene and coke formation [2].
- **Hydrocarbon Partial Pressure:** Steam serves as an **inert diluent** that reduces hydrocarbon partial pressure, thereby shifting equilibrium toward olefin formation while simultaneously suppressing coke deposition [2]. Typical steam-to-hydrocarbon ratios range from 0.25–0.40 for gaseous feeds to 0.6–1.0 for liquid feedstocks [2] [5].

Table 1: Effect of Feedstock Type on Ethylene Steam Cracking Product Yields

Feedstock	Ethylene Yield (wt%)	Propylene Yield (wt%)	Butadiene Yield (wt%)	Aromatics Yield (wt%)	Other Products (wt%)
Ethane	77-82%	2-4%	1-2%	0-1%	15-20%
Propane	42-47%	14-17%	3-4%	3-5%	30-35%
Naphtha	30-35%	14-17%	4-6%	12-16%	30-35%
LPG	38-45%	16-20%	4-5%	4-6%	25-35%

Source: Adapted from [1] [2]

## Industrial Process Implementation

## Equipment and Process Flow

The steam cracking process employs sophisticated **integrated systems** comprising multiple unit operations designed to handle extreme temperatures and complex separations. The heart of an ethylene plant is the **cracking furnace**, where tubular reactors made of high-alloy materials withstand temperatures exceeding 800°C while containing the pyrolysis reactions [1]. These furnaces feature two distinct sections: a **convection section** where feedstocks are preheated and mixed with dilution steam, and a **radiation section** where burners provide the intense heat required for pyrolysis [2]. Following cracking, the effluent stream undergoes **rapid quenching** in transfer line exchangers (TLEs) that cool the gases from 800°C to 350–450°C within milliseconds to "freeze" the reaction products and prevent degradation of ethylene yield [2].

The quenched gas then progresses through a series of **separation and purification stages**. First, a primary fractionator separates heavier hydrocarbons (pyrolysis gasoline and fuel oil), while the cracked gas is compressed in multi-stage compressors [2] [6]. Acid gas removal units employing amine solvents extract carbon dioxide and hydrogen sulfide, followed by drying to prevent ice formation during cryogenic separation [2]. The **fractionation train** typically includes a demethanizer (removing hydrogen and methane), deethanizer (separating C<sub>2</sub> components), depopanizer (separating C<sub>3</sub> components), and debutanizer (separating C<sub>4</sub> components) [2] [6]. Finally, **cryogenic distillation** columns operating at temperatures as low as -165°C produce polymer-grade ethylene (99.9% purity) through a complex arrangement of heat exchangers and separation towers [6].

## Process Control and Optimization

Modern ethylene plants implement sophisticated **control strategies** to maintain optimal operation amid varying feedstock compositions and market demands. **Distributed Control Systems (DCS)** form the backbone of plant automation, while **Advanced Process Control (APC)** systems leverage real-time data to stabilize operations and optimize energy consumption [1]. Emerging **data-driven modeling** approaches incorporate machine learning techniques to develop surrogate models that predict product yields based on operating conditions and feedstock properties [7]. These digital technologies enable implementation of **predictive maintenance** programs that anticipate equipment failures and schedule decoking operations with minimal disruption to production [1].

The development of **intelligent modeling frameworks** represents a significant advancement in steam cracking optimization. These systems integrate feature engineering, data clustering, and multivariate adaptive regression splines (MARS) to create accurate predictive models from industrial operating data [7]. By applying **k-means clustering** to feedstock-related features such as paraffin-to-isoparaffin ratio and average boiling point, these frameworks can partition operational data into distinct regimes, enabling the development of customized models for each operating region [7]. The resulting systems demonstrate enhanced prediction accuracy for key performance indicators including ethylene yield, energy consumption, and product distribution, facilitating real-time optimization of the cracking process [7].

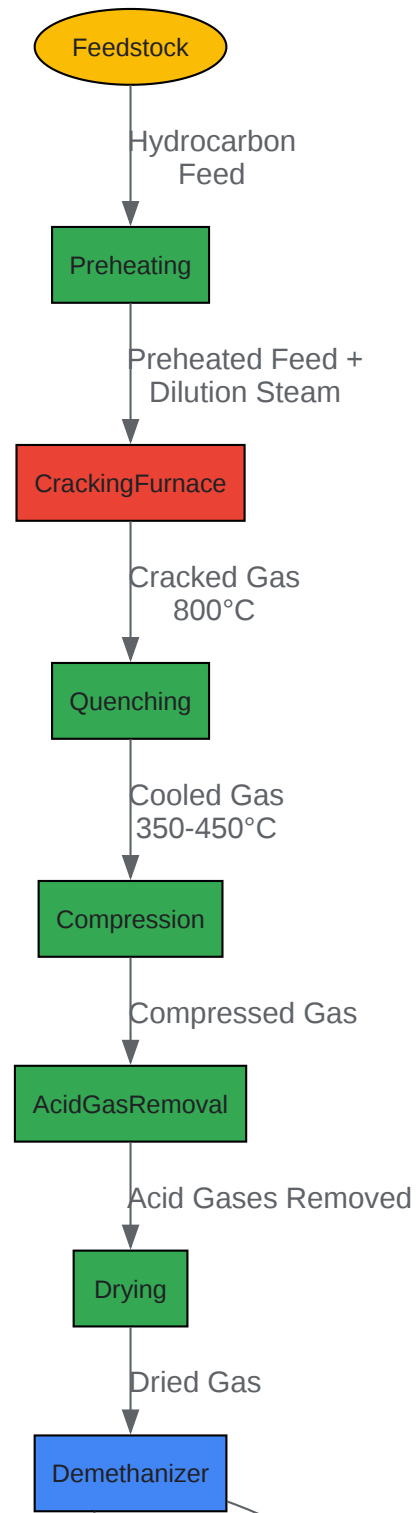

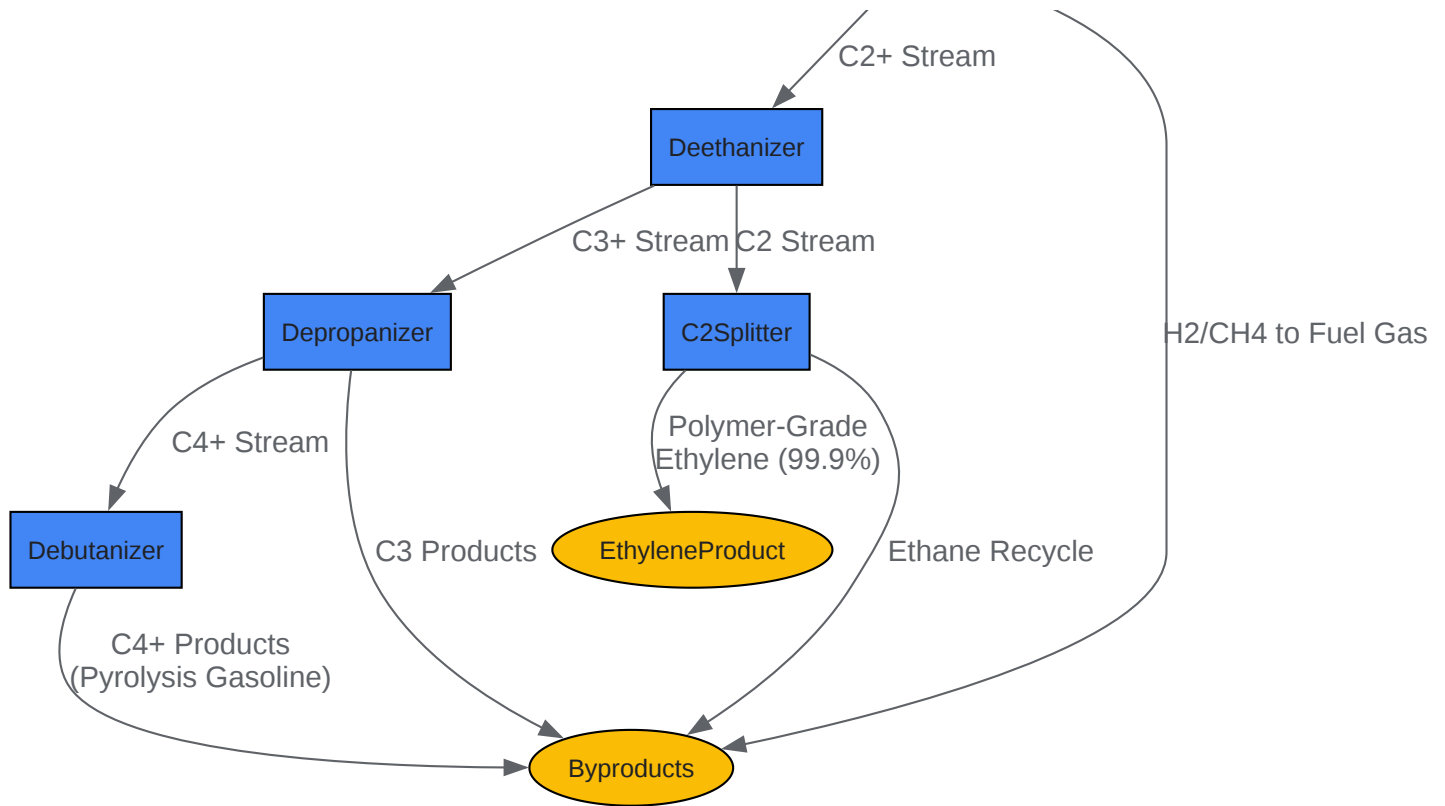

[Click to download full resolution via product page](#)

Figure 1: Steam Cracking Process Flow Diagram

## Experimental Protocols and Methodologies

### Protocol: Cracking Severity Assessment and Yield Determination

**Purpose:** This protocol establishes a standardized methodology for determining the cracking severity and product yield distribution of hydrocarbon feedstocks under controlled steam cracking conditions. The

procedure enables researchers to quantify the relationship between operational parameters (temperature, residence time, steam-to-hydrocarbon ratio) and resulting product spectra [7] [2].

### Materials and Equipment:

- Laboratory-scale steam cracking reactor system with radiant heating capability
- Mass flow controllers for hydrocarbon and steam feeds
- Preheater system for feedstock vaporization
- Quartz or ceramic reactor tube capable of withstanding  $>1000^{\circ}\text{C}$
- Rapid quenching system (transfer line heat exchanger)
- Online gas chromatography system with TCD and FID detectors
- Temperature and pressure monitoring instruments calibrated to reference standards

### Experimental Procedure:

- **System Preparation:** Clean the reactor tube to remove carbon deposits. Verify leak integrity of the entire system up to operating pressure. Calibrate all measurement devices using certified reference materials.
- **Feedstock Characterization:** Determine key properties of the hydrocarbon feedstock including paraffin-isoparaffin ratio (P/I), average boiling point, and composition distribution [7].
- **Parameter Setting:** Establish target operating conditions including coil outlet temperature ( $750\text{--}900^{\circ}\text{C}$ ), residence time ( $0.1\text{--}0.5\text{ s}$ ), and steam-to-hydrocarbon ratio ( $0.3\text{--}0.8\text{ w/w}$ ) based on experimental objectives [2].
- **System Startup:** Initiate steam flow to establish the desired dilution ratio. Gradually increase reactor temperature to the target while maintaining continuous steam flow. Introduce hydrocarbon feedstock once stable temperature conditions are achieved.
- **Data Collection:** After achieving steady-state conditions (typically  $30\text{--}60\text{ minutes}$ ), collect product samples for analysis. Record temperature profiles, pressure readings, and flow rates at 5-minute intervals.
- **Product Analysis:** Quantify product composition using calibrated gas chromatography. Apply response factors to determine absolute concentrations of all significant components from hydrogen to

C6+ hydrocarbons.

- **Yield Calculation:** Calculate product yields on a mass and molar basis using internal standard methods. Determine key performance metrics including ethylene selectivity, conversion rate, and cracking severity indices.

**Data Analysis:** Calculate cracking severity using the relationship:  $\text{Severity} = f(T, t) = k \cdot t$ , where  $k$  is the first-order rate constant for naphtha disappearance,  $T$  is temperature, and  $t$  is residence time [2]. Correlate severity indices with product yield patterns to establish predictive models for industrial operation.

## Protocol: Data-Driven Modeling for Steam Cracking Optimization

**Purpose:** This protocol outlines the development of machine learning models for predicting steam cracking performance based on industrial operational data. The approach integrates domain knowledge with statistical learning techniques to create interpretable models for yield prediction and optimization [7].

### Data Collection and Preprocessing:

- **Industrial Data Acquisition:** Collect historical operating data from distributed control systems (DCS), including temperatures, pressures, flow rates, and feedstock properties [7].
- **Data Cleansing:** Apply outlier detection methods and data validation rules to identify and address erroneous measurements. Implement missing data imputation techniques for incomplete records [7].
- **Feature Engineering:** Generate domain-specific features including paraffin-to-isoparaffin ratio (P/I), paraffin plus isoparaffin content (P+I), aromatic content (A), volume average boiling point (VABP), and steam-to-hydrocarbon ratio [7]. Transform raw measurement data into physically meaningful variables that enhance model interpretability.

### Clustering and Model Development:

- **Feedstock Clustering:** Apply k-means clustering to partition the industrial dataset based on feedstock-related features. Determine optimal cluster number using silhouette analysis [7].
- **Model Training:** Implement Multivariate Adaptive Regression Splines (MARS) with iterative outlier removal (LARD-MARS algorithm) to develop predictive models for each feedstock cluster [7].
- **Model Validation:** Evaluate model performance using k-fold cross-validation. Compare prediction accuracy against traditional first-principles models and alternative machine learning approaches.

**Implementation:** Deploy validated models for real-time optimization of industrial steam cracking operations. Integrate with existing control systems to provide operational recommendations for maximizing ethylene yield while minimizing energy consumption and coke formation [7].

Table 2: Comparative Analysis of Ethylene Production Technologies

Technology	Energy Consumption (GJ/t ethylene)	CO2 Emissions (kg CO2e/kg ethylene)	Capital Cost Relative to Conventional	Technology Readiness Level	Key Challenges
Conventional Steam Cracking	16-23	0.9-2.0	Baseline (1.0)	9 (Commercial)	High emissions, Energy intensity
Electrified Steam Cracking	12-18 (electricity)	0.2-1.3*	0.8-1.2	4-6 (Pilot)	Electricity cost, High-temp materials
Oxidative Dehydrogenation (ODHE)	8-12	1.5-2.5	0.7-1.0	5-7 (Demonstration)	Ethylene loss, Oxygen handling
Bio-ethylene (Ethanol Dehydration)	25-40	0.5-1.5	1.5-2.5	8 (Commercial)	Feedstock cost, Scale limitations

Source: [8] [5] [3]; \*Highly dependent on grid emission factor; Carbon neutral if biogenic carbon considered

## Emerging Technologies and Decarbonization Strategies

### Electrified Steam Cracking Technologies

The **electrification of steam cracking** represents a promising pathway for reducing the carbon footprint of ethylene production. Conventional cracking furnaces rely on fossil fuel combustion for process heat, generating direct CO<sub>2</sub> emissions of approximately 0.4–1.6 kg CO<sub>2</sub>e per kg of ethylene [3]. **Electrified steam cracking** (ESC) technologies replace combustion heating with electric resistance heating systems, potentially eliminating direct emissions when powered by renewable electricity [8]. Recent multi-scale assessments of **internal electric-resistance-heated** (i-ERH) reactors indicate that ESC can achieve 17.8% lower feedstock consumption while simultaneously increasing ethylene yield compared to conventional thermal steam cracking [8]. These performance improvements stem from more precise temperature control and enhanced heat transfer characteristics, which reduce undesirable secondary reactions [8].

The **economic viability** of electrified cracking is highly sensitive to electricity prices and carbon policy frameworks. Techno-economic analyses indicate that ESC becomes competitive with conventional steam cracking at electricity prices below \$41–57 per MWh, with optimal economics achieved when reactors are specifically designed to maximize ethylene yield rather than simply replicating thermal cracking performance [8] [3]. From an **environmental perspective**, the carbon footprint of electrified cracking is directly tied to the emissions intensity of the electricity source. Under 2022 Texas grid conditions (approximately 0.38 tCO<sub>2</sub>e/MWh), ESC emissions would be 53.4% higher than conventional cracking, but would achieve 20.5–47.7% lower emissions under projected 2035 grid scenarios with higher renewable penetration [8]. Life-cycle assessment studies indicate that electrified cracking achieves carbon neutrality when the grid emission intensity falls below 60 kgCO<sub>2</sub>e/MWh [3].

## Alternative Process Routes and Sustainability Initiatives

Beyond electrification, several **alternative production pathways** are under development to improve the sustainability of ethylene manufacturing. The **oxidative dehydrogenation of ethane** (ODHE) has attracted significant research interest due to its lower energy requirements and inherent coke suppression enabled by the co-fed oxygen [5]. While ODHE demonstrates economic competitiveness with a minimum selling price of \$790 per ton of ethylene compared to \$832 for conventional steam cracking, current implementations face environmental challenges due to the significant refrigeration input required for ethylene recovery from byproducts such as CO, CH<sub>4</sub>, and unreacted oxygen [5]. However, scenario analyses indicate that improvements in single-pass conversion, ethylene selectivity, and feed ratio optimization could render ODHE both economically and environmentally superior to conventional steam cracking [5].

**Bio-ethylene production** via ethanol dehydration has emerged as a commercial alternative in specific regions, particularly Brazil and parts of Europe, where abundant sugarcane ethanol provides an economical renewable feedstock [1]. This pathway offers a **circular economy** approach to ethylene production while providing a drop-in replacement for petrochemical-derived ethylene without compromise to material properties [1]. Additional decarbonization strategies gaining traction include the integration of **carbon capture and storage** (CCS) systems with conventional steam crackers, which can reduce emissions by 20–40% depending on implementation scope [3]. The application of CCS specifically to purge gas streams represents a particularly cost-effective approach, achieving emissions reductions of 19–30% with a levelized cost of ethylene increase of only 3–5% [3].

## Industry Context and Future Outlook

### Market Dynamics and Competitive Landscape

The global ethylene industry is experiencing a **prolonged downcycle** characterized by oversupply conditions and margin compression. Current operating rates have fallen to approximately 84% in 2025, a significant decline from the >90% rates observed prior to 2019 [4]. This **structural surplus** is largely attributable to substantial capacity expansions in China, which have dramatically altered global trade patterns and profitability metrics [4]. The return on investment for ethylene-high-density polyethylene integrated plants in China is projected to reach a record low of -11% in 2026, with positive returns unlikely before 2032 [4]. These challenging market conditions have created intense **rationalization pressure**, particularly on older, less efficient assets in Europe and Asia [4].

Regional production dynamics continue to evolve in response to **feedstock availability** and energy considerations. North American producers maintain a competitive advantage through access to ethane derived from shale gas, while Middle Eastern facilities leverage integration with upstream natural gas operations [1] [3]. In contrast, European producers face **structural disadvantages** due to higher energy costs, weaker demand growth, and increasing competition from imported products [4]. Current projections indicate that 12% of European ethylene capacity will be shuttered by 2028, with an additional 13% of total capacity currently offered for sale [4]. Similar rationalization trends are evident in Asia, where approximately 11 million tons of Chinese ethylene capacity faces closure risk through 2030 under energy-saving and carbon-reduction regulations [4].

## Environmental Regulations and Sustainability Trajectory

The ethylene industry faces increasing **regulatory pressure** to address its environmental footprint, particularly its energy intensity and greenhouse gas emissions. Conventional steam cracking generates 1–2 tons of CO<sub>2</sub>-equivalent emissions per ton of ethylene produced, making ethylene the second-largest contributor to industrial emissions within the chemical sector [3]. In response to these challenges, major producers are implementing **comprehensive sustainability initiatives** including ISO 14001-certified environmental management systems, flaring reduction programs, and enhanced emissions monitoring [1]. The industry's future development will likely be shaped by evolving policy frameworks including carbon border adjustment mechanisms, emissions trading systems, and product sustainability standards [1] [4].

### **Need Custom Synthesis?**

Email: [info@smolecule.com](mailto:info@smolecule.com) or [Request Quote Online](#).

## References

1. Ethylene Production Process: From Cracking to Critical ... [chemanalyst.com]
2. Ethylene Production and Its Role in Shaping the Modern ... [aiche.org]
3. Decarbonization approaches for ethylene production [pubs.rsc.org]
4. Quantifying the steam cracker closure threat [woodmac.com]
5. Ethylene production: process design, techno-economic and ... [pubs.rsc.org]
6. Ethylene Plant - an overview [sciencedirect.com]
7. Data-driven intelligent modeling framework for the steam ... [sciencedirect.com]
8. Comparative reactor, process, techno-economic, and life ... [chemrxiv.org]

To cite this document: Smolecule. [Comprehensive Application Notes and Protocols: Industrial Ethylene Production via Steam Cracking]. Smolecule, [2026]. [Online PDF]. Available at:

[<https://www.smolecule.com/products/b595908#ethylene-industrial-production-steam-cracking-process>]

---

## Disclaimer & Data Validity:

The information provided in this document is for Research Use Only (RUO) and is strictly not intended for diagnostic or therapeutic procedures. While Smolecule strives to provide accurate protocols, we make no warranties, express or implied, regarding the fitness of this product for every specific experimental setup.

**Technical Support:** The protocols provided are for reference purposes. Unsure if this reagent suits your experiment? [Contact our Ph.D. Support Team for a compatibility check]

**Need Industrial/Bulk Grade?** Request Custom Synthesis Quote

## Smolecule

Your Ultimate Destination for Small-Molecule (aka. smolecule) Compounds, Empowering Innovative Research Solutions Beyond Boundaries.

## Contact

**Address:** Ontario, CA 91761, United States  
**Phone:** (512) 262-9938  
**Email:** [info@smolecule.com](mailto:info@smolecule.com)  
**Web:** [www.smolecule.com](http://www.smolecule.com)