

Application Notes: Synthetic Strategies for Heterodectic Macrocyclic Peptides

Author: Smolecule Technical Support Team. **Date:** February 2026

Compound Focus: Piperazinomycin

CAS No.: 83858-82-6

Cat. No.: S588498

[Get Quote](#)

Heterodectic macrocyclic peptides are a class of constrained peptides where the ring closure occurs through a bond other than a standard amide (peptide) bond, such as an ether or disulfide linkage. These structures are crucial in drug discovery due to their enhanced metabolic stability, receptor selectivity, and cell permeability compared to their linear counterparts [1].

Piperazinomycin as a Model Heterodectic Peptide Piperazinomycin is a fungal-derived antibiotic natural product that exemplifies a highly strained heterodectic macrocycle [2]. Its structure is characterized by a **reduced piperazine core** and a critical **aryl-alkyl ether bond** that crosslinks the tyrosine side chains, contributing to its rigid, bowl-shaped conformation and biological activity [2]. The biosynthesis of related strained peptides like Herquiline A involves a P450 enzyme (e.g., Hq1C) that catalyzes the oxidative coupling of aryl rings, a process that can inspire biomimetic synthetic strategies [2].

Comparative Advantages of Synthetic Methodologies

- **S_NAr Cycloetherification:** This chemical method is powerful for constructing biaryl ether linkages found in complex natural products like vancomycin. It tackles two challenging synthetic problems—ether bond formation and macrocyclization—in a single operation, offering high convergence and atom economy [3] [4].
- **Chemoenzymatic Macrocyclization:** This approach leverages the efficiency and selectivity of enzymatic catalysis, such as Thioesterase (TE) domains. TE domains pre-organize linear peptide substrates, facilitating high-yielding cyclization with minimal epimerization and reducing issues like oligomerization common in chemical macrocyclization [5].

Detailed Experimental Protocols

Protocol 1: SNAr-Based Cycloetherification for Aryl-Ether Bond Formation

This protocol describes the synthesis of heterodetic macrocyclic peptides featuring endo aryl-aryl or aryl-alkyl ether bonds, characteristic of peptides like the vancomycin family [3] [4].

Materials

- Linear peptide precursor containing an electron-deficient aryl halide (e.g., fluoro- or nitro-substituted) and a phenolic nucleophile.
- Anhydrous, aprotic solvent (e.g., DMF, DMSO, or acetonitrile).
- Base (e.g., cesium carbonate or potassium carbonate).
- Source of inert atmosphere (e.g., nitrogen or argon gas).

Procedure

- **Synthesis of Linear Precursor:** Synthesize the protected linear peptide sequence containing the requisite electron-deficient aryl halide and phenolic nucleophile using standard Fmoc-SPPS protocols.
- **Cyclization Reaction:** a. Dissolve the linear peptide precursor in anhydrous DMF at a concentration of 0.5-1.0 mM to favor intramolecular reaction. b. Add 2.0-3.0 equivalents of cesium carbonate under an inert atmosphere. c. Stir the reaction mixture at room temperature or elevated temperature (e.g., 40-60°C), monitoring by LC-MS until completion.
- **Work-up and Purification:** Upon reaction completion, quench by dilution with ethyl acetate and wash with aqueous citric acid solution. Purify the crude macrocyclic product using reversed-phase preparative HPLC.

Critical Notes

- **Substrate Design:** The ring size and steric hindrance around the reactive sites must be carefully considered to achieve successful cyclization.
- **Minimize Oligomerization:** Using high-dilution conditions (slow addition of precursor to the reaction vessel) is crucial to suppress intermolecular dimerization or oligomerization.

The workflow for this synthetic approach is outlined below:

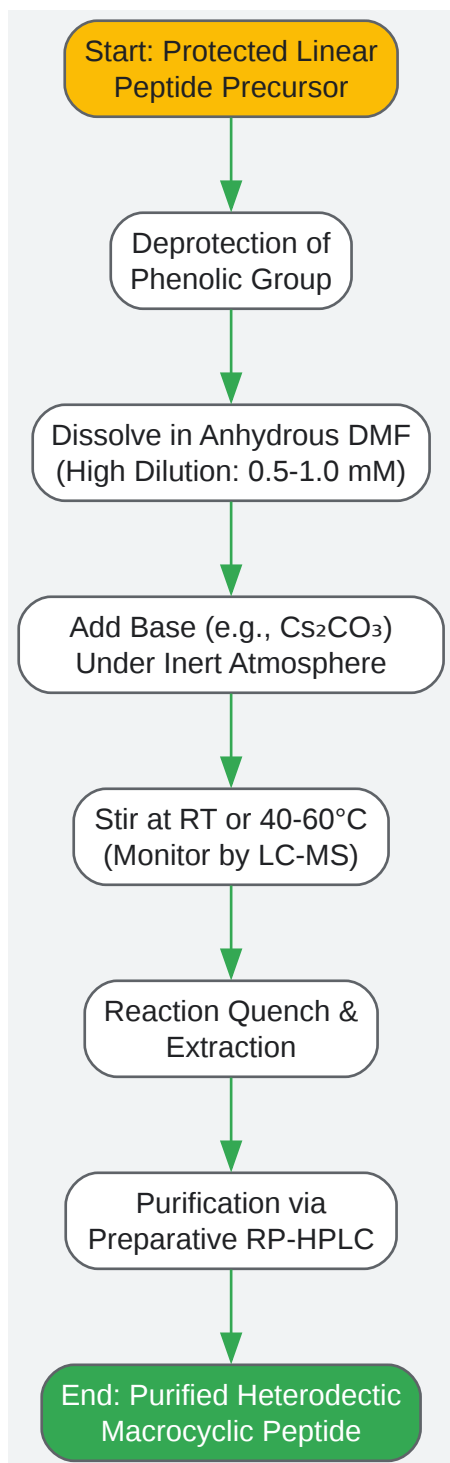

[Click to download full resolution via product page](#)

Protocol 2: Chemoenzymatic Macrocyclization Using Thioesterase (TE) Domains

This protocol utilizes TycC TE to catalyze the head-to-tail macrocyclization of a linear decapeptide-SNAC thioester into Tyrocidine A, a method applicable to **piperazinomycin** analogs [5].

Materials

- Linear peptide-N-acetylcysteamine (SNAC) thioester substrate.
- Purified TycC TE domain (or other relevant TE).
- Assay buffer (e.g., Tris-HCl or phosphate buffer, pH 7.0-8.5).
- NADPH (if required by specific SDR enzymes in cascade reactions).

Procedure

- **Synthesis of Peptide-SNAC Substrate:** a. Synthesize the linear peptide sequence on 2-chlorotrityl resin using Fmoc-SPPS. b. Cleave the peptide from the resin while preserving side-chain protections. c. Couple the free C-terminal carboxylate with N-acetylcysteamine (NAC) to form the peptide-SNAC thioester. d. Fully deprotect and purify the linear peptide-SNAC by HPLC.
- **Enzymatic Macrocyclization:** a. Prepare a solution of the purified peptide-SNAC substrate (0.1-0.5 mM) in a suitable assay buffer. b. Add the purified TycC TE domain (final concentration ~1-5 μ M). c. Incubate the reaction at 25-30°C for 1-4 hours.
- **Reaction Monitoring and Purification:** Monitor the consumption of the linear substrate and formation of the macrocyclic product by LC-MS. Upon completion, purify the reaction mixture using reversed-phase preparative HPLC.

Critical Notes

- **Substrate Scope:** TE domains can exhibit broad substrate tolerance, allowing for the incorporation of non-native amino acids to create analog libraries. However, they are often more sensitive to changes near the cyclization site [5].
- **Minimizing Epimerization:** The chemoenzymatic approach is advantageous for minimizing C α epimerization, a common issue in chemical macrolactamization [5].

The relationship between these methods and their application to target structures is illustrated below:

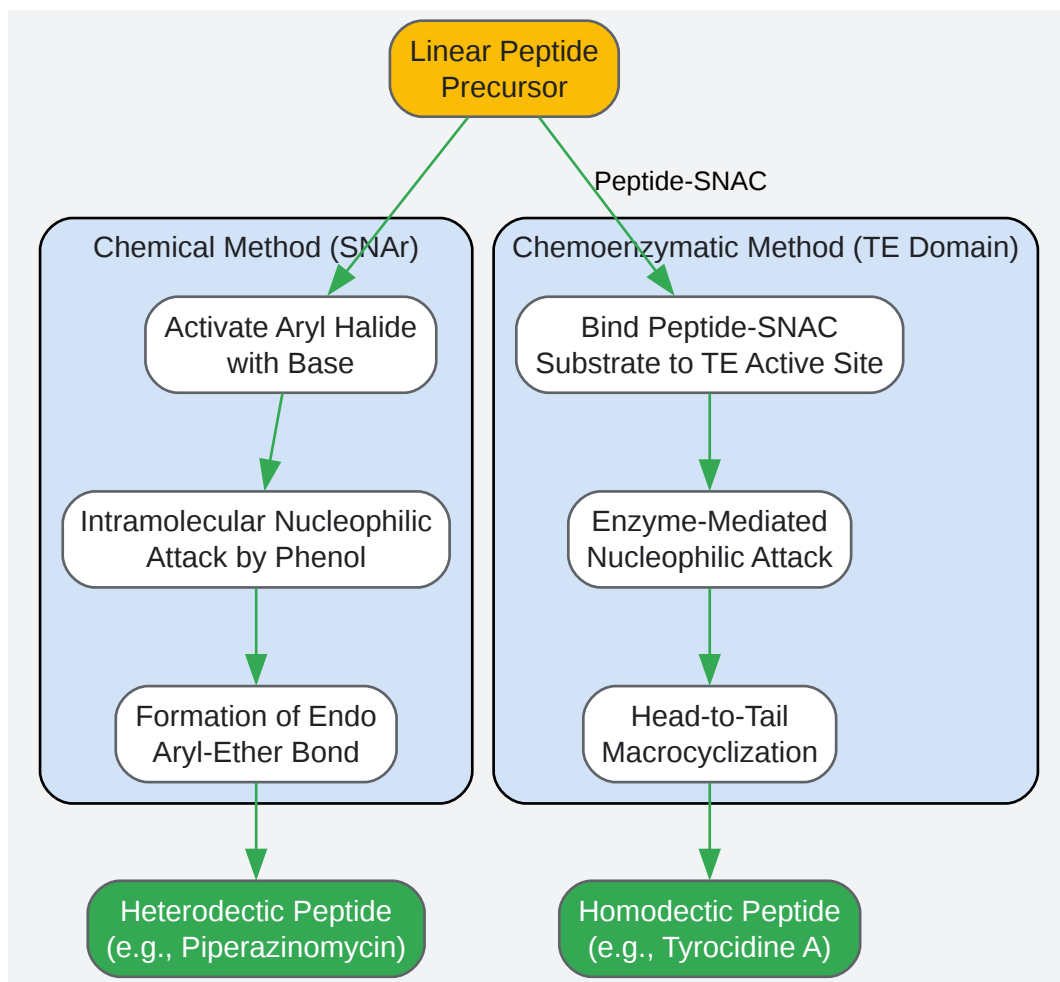

[Click to download full resolution via product page](#)

Key Data and Optimization Parameters

Table 1: Key Parameters for S_NAr Cycloetherification Protocol

Parameter	Optimal Condition	Notes & Variations
Concentration	0.5 - 1.0 mM	High dilution favors intramolecular cyclization over polymerization.
Base	CS_2CO_3	Other bases like K_2CO_3 or DBU can be effective.

Parameter	Optimal Condition	Notes & Variations
Solvent	Anhydrous DMF or DMSO	Essential to maintain anhydrous conditions to prevent hydrolysis.
Temperature	Room Temp. to 60°C	Higher temperatures may be needed for sterically hindered substrates.
Reaction Time	2 - 24 hours	Monitor by LC-MS/TLC for completion.

Table 2: Key Parameters for Chemoenzymatic Macrocyclization Protocol

Parameter	Optimal Condition	Notes & Variations
Substrate	Peptide-SNAC thioester	CoA, phosphopantetheine, or thiophenol thioesters are alternatives [5].
[Substrate]	0.1 - 0.5 mM	Varies with enzyme efficiency and substrate solubility.
TE Domain	TycC TE (for Tyrocidine)	SnbDE TE for streptogramins; Sgd TE for seongsanamide [5].
Buffer pH	7.0 - 8.5 (Tris or Phosphate)	Match the optimal pH for the specific TE domain used.
Incubation Time	1 - 4 hours	Generally faster than chemical methods with fewer side reactions.

Troubleshooting and Technical Notes

- **Low Cyclization Yields in S_NAr :** If yields are low, consider synthesizing analogs with different ring sizes or introducing electron-withdrawing groups (e.g., nitro) on the aryl halide to enhance its reactivity. Re-optimize concentration and base strength [3] [4].
- **Hydrolysis vs. Cyclization in TE Reactions:** If hydrolysis of the peptide-SNAC substrate is a significant side reaction, consider using nonionic detergents in the reaction buffer or exploring mutations of key residues in the TE's active site to favor macrocyclization [5].

- **Handling Peptide-SNAC Substrates:** Peptide-SNAC thioesters can be prone to epimerization and are challenging to purify. As an alternative, solid-phase synthesis with a biomimetic linker that mimics the native peptidyl carrier protein (PCP) can be employed for a more robust and efficient process [5].

Conclusion

The synthesis of heterodectic macrocyclic peptides like **Piperazinomycin** can be achieved through complementary synthetic biology and chemical strategies. The **S_NAr-based cycloetherification** is a powerful chemical tool for directly forging the critical endo ether bonds, while **chemoenzymatic approaches using TE domains** offer a highly efficient and potentially more biomimetic route for macrocyclization. The choice of method depends on the specific target structure, available resources, and desired analog libraries. These detailed protocols provide a foundation for researchers to explore and produce these complex, biologically active molecules.

Need Custom Synthesis?

Email: info@smolecule.com or Request Quote Online.

References

1. - Creative Macrocyclic Peptides Synthesis Peptides [creative-peptides.com]
2. Biosynthesis of Strained Piperazine Alkaloids - PubMed Central [pmc.ncbi.nlm.nih.gov]
3. S(N) Ar-based cycloetherification methodology: application in the... [pubmed.ncbi.nlm.nih.gov]
4. S_NAr-Based Cycloetherification Methodology: Application in the ... [link.springer.com]
5. BJOC - Chemoenzymatic synthesis of macrocyclic and... peptides [beilstein-journals.org]

To cite this document: Smolecule. [Application Notes: Synthetic Strategies for Heterodectic Macrocyclic Peptides]. Smolecule, [2026]. [Online PDF]. Available at:

[<https://www.smolecule.com/products/b588498#heterodectic-macrocyclic-peptides-synthesis-piperazinomycin>]

Disclaimer & Data Validity:

The information provided in this document is for Research Use Only (RUO) and is strictly not intended for diagnostic or therapeutic procedures. While Smolecule strives to provide accurate protocols, we make no warranties, express or implied, regarding the fitness of this product for every specific experimental setup.

Technical Support: The protocols provided are for reference purposes. Unsure if this reagent suits your experiment? [Contact our Ph.D. Support Team for a compatibility check]

Need Industrial/Bulk Grade? Request Custom Synthesis Quote

Smolecule

Your Ultimate Destination for Small-Molecule (aka. smolecule) Compounds, Empowering Innovative Research Solutions Beyond Boundaries.

Contact

Address: Ontario, CA 91761, United States

Phone: (512) 262-9938

Email: info@smolecule.com

Web: www.smolecule.com