

what is 1,3-Diacetoxypropane

Author: Smolecule Technical Support Team. **Date:** February 2026

Compound Focus: 1,3-Diacetoxypropane

CAS No.: 628-66-0

Cat. No.: S579597

Get Quote

Molecular Characterization

Property	Value
CAS Number	628-66-0 [1]
IUPAC Name	3-acetyloxypropyl acetate [2]
Molecular Formula	C ₇ H ₁₂ O ₄ [1] [2]
Molecular Weight	160.17 g/mol [1] [2]
Exact Mass	160.073559 g/mol [2]
Boiling Point	209-210°C [1]
Density	1.06 g/cm ³ [1]
Flash Point	97.5°C [1]
Index of Refraction	1.417 [1]
Solubility	0.62 M [2]

Structural Configuration

The molecule consists of a three-carbon propane backbone with an acetoxy group ($-OC(=O)C$) attached to each terminal carbon [2]. Its canonical SMILES representation is CC(=O)OCCOC(=O)C [2]. The structural diagram below illustrates the connectivity of atoms and symmetrical ester functional groups.

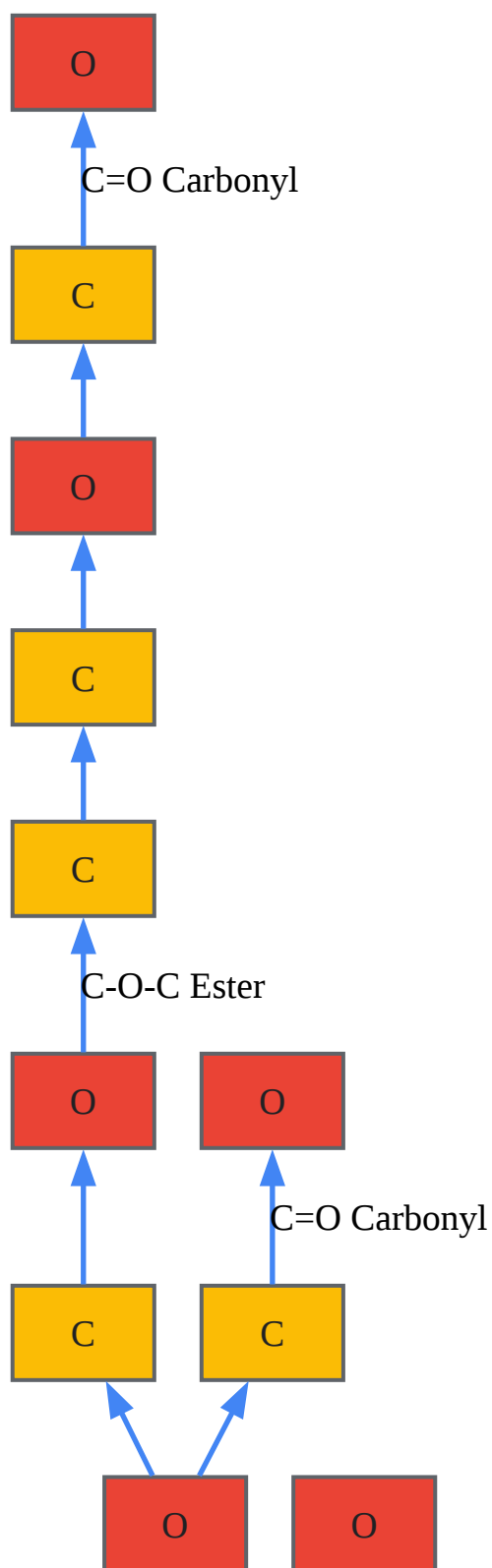

[Click to download full resolution via product page](#)

Synthesis and Production

1,3-Diacetoxypropane is synthesized through esterification reactions, with two common methods detailed below [2].

Direct Esterification

- **Reactants:** Propane-1,3-diol and Acetic Acid [2]
- **Catalyst:** Acid catalyst (e.g., sulfuric acid) [2]
- **Condition:** Controlled temperature [2]

Acetic Anhydride Method

- **Reactants:** Propane-1,3-diol and Acetic Anhydride [2]
- **By-product:** Acetic Acid [2]

The following diagram maps the synthesis pathways and their relationships.

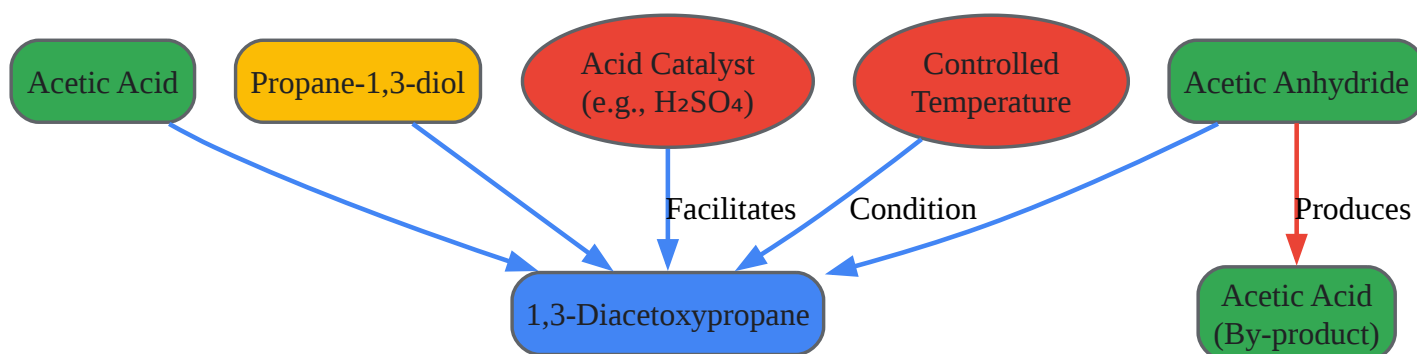

[Click to download full resolution via product page](#)

Experimental Protocols

Protocol 1: Synthesis via Direct Esterification [2]

This classic method involves a reversible reaction between a diol and a carboxylic acid.

- **Reaction Setup:** Combine propane-1,3-diol and acetic acid in a molar ratio favoring the acid (e.g., 1:2.5) in a round-bottom flask.
- **Catalysis:** Add a concentrated acid catalyst (e.g., 1-2% volume of sulfuric acid).
- **Heating & Reflux:** Attach a reflux condenser and heat the mixture with stirring (e.g., 110-120°C) for several hours.
- **Reaction Monitoring:** Monitor reaction progress by Thin-Layer Chromatography (TLC) or by measuring the water of esterification.
- **Work-up:** After cooling, neutralize the acid catalyst with a saturated sodium bicarbonate solution. Separate the organic layer.
- **Purification:** Wash the organic layer with brine, dry over anhydrous magnesium sulfate, and filter. Purify the crude product via distillation under reduced pressure, collecting the fraction around 209-210°C.

Protocol 2: Synthesis via Acetic Anhydride [2]

This method uses a more reactive acylating agent and is often faster and less reversible.

- **Reaction Setup:** Add propane-1,3-diol to acetic anhydride in a molar ratio (e.g., 1:2.2) in a round-bottom flask.
- **Catalysis:** Add a catalytic amount of an acid (sulfuric acid) or base (pyridine) to initiate the reaction.
- **Stirring:** Stir the reaction mixture at room temperature or under mild heating (40-60°C) for 1-3 hours.
- **Work-up:** Quench the reaction by carefully adding water or a cold aqueous solution to destroy excess acetic anhydride.
- **Extraction:** Extract the product using an organic solvent (e.g., dichloromethane or ethyl acetate).
- **Purification:** Wash the organic extracts with brine, dry over anhydrous magnesium sulfate, and filter. Remove the solvent by rotary evaporation. Further purify via distillation for high-purity product.

Analytical Characterization

For conclusive identification, characterize the synthesized product using these techniques [2].

- **Gas Chromatography-Mass Spectrometry (GC-MS):** The primary fragmentation ion is at **m/z 43** (CH_3CO^+) [2].
- **Nuclear Magnetic Resonance (NMR) Spectroscopy:**
 - **^1H NMR:** δ 2.05 ppm (acetyl methyl groups), δ 4.15–4.30 ppm (methylene protons adjacent to ester groups) [2].

- **^{13}C NMR:** Characteristic signals for carbonyl carbons (~170-175 ppm), methyl carbons (~20 ppm), and methylene carbons in the backbone (60-65 ppm) [2].

Applications and Relevance

1,3-Diacetoxypropane serves primarily in industrial and research settings [2].

- **Chemical Intermediate:** Serves as a precursor for synthesizing other compounds, historically as a precursor to 1,3-propanediol for polyester production [2].
- **Solvent:** Used as a solvent in organic reactions due to its solubility properties [2].
- **Flavoring Agent:** May be used as a flavoring agent in food chemistry due to its ester characteristics [2].
- **Prodrug Potential:** The ester groups make it a potential prodrug; enzymatic hydrolysis could release acetic acid and propanediol in biological systems, though this requires more research [2].

Relationship to Key Bioprocesses

While **1,3-diacetoxypropane** itself is typically produced chemically, it is structurally related to compounds derived from glycerol, a major by-product of biodiesel production [3] [4]. Glycerol can be converted by microorganisms into 1,3-propanediol (a key industrial chemical), which is a direct parent compound of **1,3-diacetoxypropane** [4].

Need Custom Synthesis?

Email: info@smolecule.com or [Request Quote Online](#).

References

1. CAS No. 628-66-0 | Chemsrsc [chemsrc.com]
2. Buy 1,3-Diacetoxypropane | 628-66-0 [smolecule.com]
3. Production of bacterial cellulose from glycerol [pmc.ncbi.nlm.nih.gov]
4. Progress in 1,3-propanediol biosynthesis - PMC [pmc.ncbi.nlm.nih.gov]

To cite this document: Smolecule. [what is 1,3-Diacetoxypropane]. Smolecule, [2026]. [Online PDF].
Available at: [<https://www.smolecule.com/products/b579597#what-is-1-3-diacetoxypropane>]

Disclaimer & Data Validity:

The information provided in this document is for Research Use Only (RUO) and is strictly not intended for diagnostic or therapeutic procedures. While Smolecule strives to provide accurate protocols, we make no warranties, express or implied, regarding the fitness of this product for every specific experimental setup.

Technical Support: The protocols provided are for reference purposes. Unsure if this reagent suits your experiment? [Contact our Ph.D. Support Team for a compatibility check]

Need Industrial/Bulk Grade? Request Custom Synthesis Quote

Smolecule

Your Ultimate Destination for Small-Molecule (aka. smolecule) Compounds, Empowering Innovative Research Solutions Beyond Boundaries.

Contact

Address: Ontario, CA 91761, United States
Phone: (512) 262-9938
Email: info@smolecule.com
Web: www.smolecule.com