

Au₂Br₆ dimeric structure explanation

Author: Smolecule Technical Support Team. **Date:** February 2026

Compound Focus: Gold tribromide

CAS No.: 10294-28-7

Cat. No.: S570179

Get Quote

Dimeric Structure Explanation

Many metal halides, including aluminium bromide (Al₂Br₆) and gold(III) bromide (Au₂Br₆), form dimers in their solid and liquid states. This occurs because the electron-deficient central metal atom can achieve a stable electron configuration by forming bridging bonds with halide atoms [1].

The structure of Al₂Br₆ involves two aluminum atoms, each bonded to two terminal bromine atoms and connected to each other by two bromine atoms that act as bridges. This results in a structure where each aluminum atom is at the center of a tetrahedron, and the two aluminum-bromine tetrahedra share a common edge, giving the overall molecule D_{2h} symmetry [1]. The diagram below illustrates this general structure for a halide-bridged dimer.

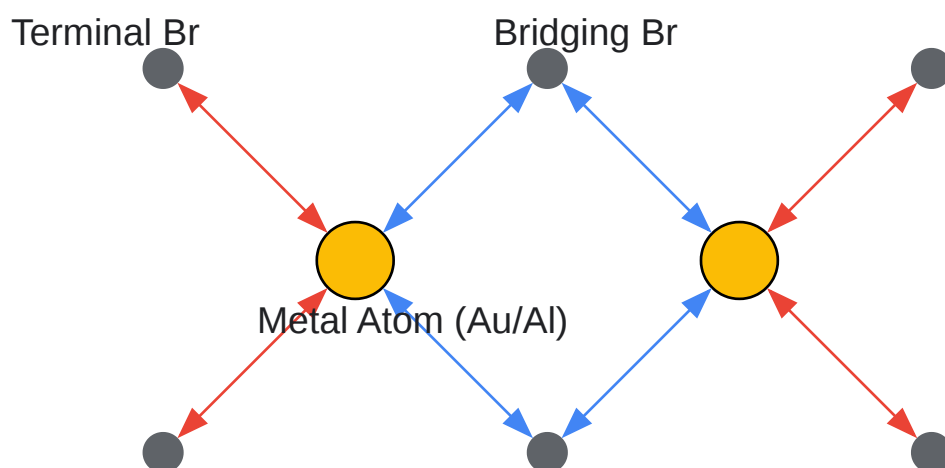

[Click to download full resolution via product page](#)

General structure of a M_2X_6 dimer ($M=Au, Al$; $X=Br$) showing edge-sharing tetrahedra

Key Properties and Quantitative Data

Based on the analogous structure of Al_2Br_6 , the following table summarizes the key quantitative and qualitative properties expected for a Au_2Br_6 dimer [1].

Property	Description & Quantitative Data
Empirical Formula	Au_2Br_6
Molar Mass	788.69 g/mol (anhydrous)
Primary State	Dimeric (Au_2Br_6) in solid state; dissociates to monomers ($AuBr_3$) at high temperatures
Molecular Symmetry	D_{2h} (in solid state)

Property	Description & Quantitative Data
Coordination Geometry	Each gold atom is in a distorted square planar environment (considering its d ⁸ electron configuration). The bromine atoms form bridges, creating a four-coordinate system.
Bonding	Two terminal Br atoms and two bridging Br atoms per Au center. Bridging bonds are longer than terminal bonds.
Lewis Acidity	Strong Lewis acid; reacts vigorously with water, alcohols, and Lewis bases.

Experimental Protocols for Synthesis and Characterization

While specific protocols for Au₂Br₆ were not found, the following methods, adapted from Al₂Br₆ synthesis and general inorganic practice, are applicable.

Direct Synthesis from Elements

This method involves the direct reaction of the metal with bromine [1].

- **Procedure:** Place high-purity gold metal in a quartz or borosilicate glass tube. Heat the tube while passing a stream of dry bromine vapor over the metal. The reaction is highly exothermic. Collect the resulting Au₂Br₆ product, which will often be a dark solid or crystalline material.
- **Chemical Equation:** $2 \text{ Au} + 3 \text{ Br}_2 \rightarrow \text{Au}_2\text{Br}_6$
- **Safety Notes:** Must be performed in a fume hood. Bromine is highly toxic and corrosive. Use appropriate personal protective equipment (PPE) including gloves and eye protection. The product is highly reactive and moisture-sensitive [1].

Characterization via X-ray Diffraction (XRD)

X-ray crystallography is the definitive technique for determining the dimeric structure in the solid state [1] [2].

- **Workflow:** The workflow for confirming the dimeric structure through XRD is a sequential process, as shown below.

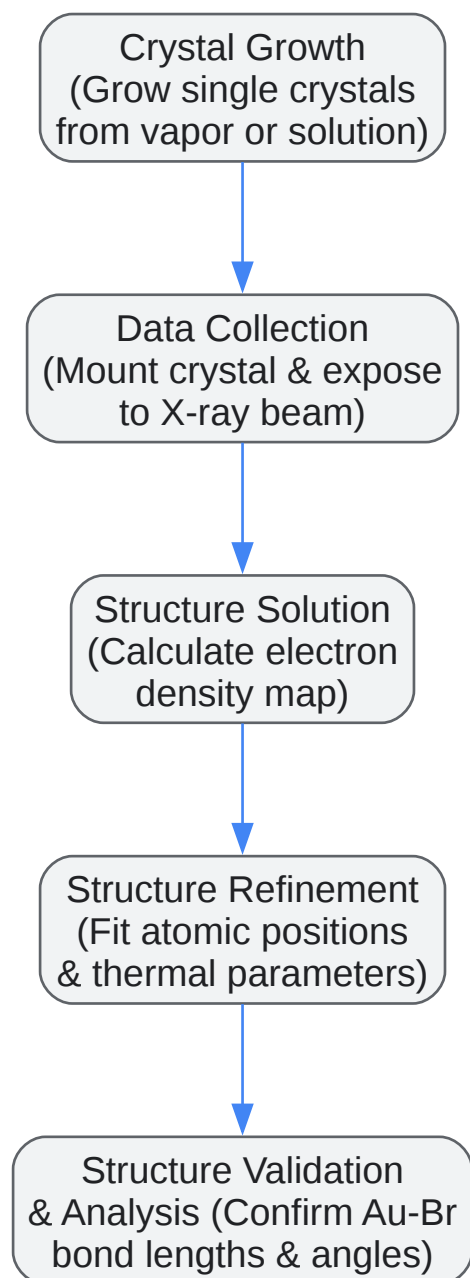

[Click to download full resolution via product page](#)

Experimental workflow for X-ray crystallography to determine dimeric structure

Research Context and Applications

The primary importance of understanding the Au_2Br_6 dimeric structure lies in its role as a precursor and catalyst in various chemical processes.

- **Catalysis:** Like Al_2Br_6 , which is a catalyst for Friedel-Crafts alkylation reactions, Au_2Br_6 and related gold compounds are potent Lewis acid catalysts in organic synthesis [1].
- **Material Precursor:** It serves as a starting material for the synthesis of other gold complexes and nanomaterials.
- **Computational Studies:** The structure can be modeled using computational methods like **Density Functional Theory (DFT)** to understand its electronic properties, bond energies, and reactivity. DFT calculations break down the total energy into components such as nuclear repulsion, electron kinetic energy, and electron-electron interactions, which is crucial for predicting the stability of the dimeric form [3].

Need Custom Synthesis?

Email: info@smolecule.com or Request Quote Online.

References

1. Aluminium bromide - Wikipedia [en.wikipedia.org]
2. RCSB PDB - 5NNM: The crystal structure of dimeric LL-37 [rcsb.org]
3. DFT [cup.lmu.de]

To cite this document: Smolecule. [Au₂Br₆ dimeric structure explanation]. Smolecule, [2026]. [Online PDF]. Available at: [<https://www.smolecule.com/products/b570179#au2br6-dimeric-structure-explanation>]

Disclaimer & Data Validity:

The information provided in this document is for Research Use Only (RUO) and is strictly not intended for diagnostic or therapeutic procedures. While Smolecule strives to provide accurate protocols, we make no warranties, express or implied, regarding the fitness of this product for every specific experimental setup.

Technical Support: The protocols provided are for reference purposes. Unsure if this reagent suits your experiment? [Contact our Ph.D. Support Team for a compatibility check]

Need Industrial/Bulk Grade? Request Custom Synthesis Quote

Smolecule

Your Ultimate Destination for Small-Molecule (aka. smolecule) Compounds, Empowering Innovative Research Solutions Beyond Boundaries.

Contact

Address: Ontario, CA 91761, United States

Phone: (512) 262-9938

Email: info@smolecule.com

Web: www.smolecule.com