

# Tetraethylammonium chloride vs tetramethylammonium chloride effects

**Author:** Smolecule Technical Support Team. **Date:** February 2026

## Compound Focus: Tetraethylammonium Chloride

CAS No.: 56-34-8

Cat. No.: S566236

Get Quote

## Comparative Guide: TEA Chloride vs. TMA Chloride

The table below summarizes the core properties and effects of these two compounds to help you select the appropriate reagent.

Feature	Tetraethylammonium (TEA) Chloride	Tetramethylammonium (TMA) Chloride
Primary Pharmacological Action	Potassium (K <sup>+</sup> ) channel blocker [1]	Cholinomimetic; mimics acetylcholine [2]
Key Observed Physiological Effects	Prolongs action potential duration; blocks K <sup>+</sup> current in nerve fibers [1].	Stimulates, then blocks neurotransmission in ganglia; acts on muscarinic receptors; causes fasciculations then paralysis in skeletal muscle [2].
Ionic Conductance Blockade	Decreases K <sup>+</sup> conductance [3]	Not typically associated with specific ionic conductance blockade [3].

Feature	Tetraethylammonium (TEA) Chloride	Tetramethylammonium (TMA) Chloride
Effect on Cochlear Potentials	Depresses endocochlear potential and cochlear microphonics [3]	Information not specified in search results
Typical Research Applications	Studying K <sup>+</sup> channels and action potential repolarization [1]; isolating Ca <sup>2+</sup> channel activity [1]	Studying nicotinic and muscarinic acetylcholine receptors [2]
Toxicity (Acute, Rodent)	Information not specified in search results	LD <sub>50</sub> (mouse, i.p.): 25 mg/kg (as chloride salt) [2]
Solubility	Soluble in water, ethanol, chloroform, acetone [1]	Soluble in water and methanol [4]

## Experimental Protocols & Mechanisms

For your experimental work, here are the key methodologies and visual mechanisms cited in the research.

### Detailed Experimental Context

- **Protocol for Isolating Ca<sup>2+</sup> Channel Activity** This protocol from the search results describes how TEA-Cl is used to isolate voltage-gated calcium channels for electrophysiological study [1].
  - **Key Steps:**
    - Use whole-cell or intracellular recording configurations.
    - **Block Voltage-Gated Na<sup>+</sup> Channels:** Add tetrodotoxin (TTX) to the extracellular solution.
    - **Block Voltage-Gated K<sup>+</sup> Channels:** Add **tetraethylammonium chloride** (TEA) to the extracellular solution and replace K<sup>+</sup> ions with Cs<sup>+</sup> in the intrapipette solution.
  - **Rationale:** This combination of pharmacological agents and ionic substitution suppresses the major currents (Na<sup>+</sup> and K<sup>+</sup>) that obscure the measurement of Ca<sup>2+</sup> currents [1].
- **Protocol for Studying K<sup>+</sup> Channel Effects** The foundational effect of TEA on action potentials is observed by directly applying it to nerve fibers, such as the squid giant axon [1].

- **Observation:** Application of TEA drastically prolongs the action potential duration without changing the resting membrane potential, resulting in an initial peak followed by a prolonged plateau phase [1].

## Mechanisms of Action

The diagrams below illustrate the core mechanisms and experimental workflows for these compounds.

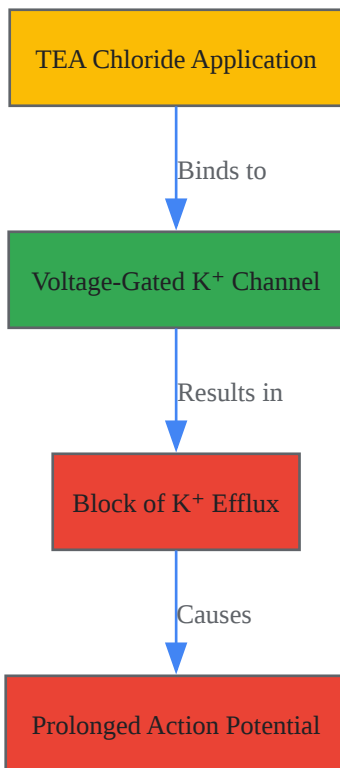

[Click to download full resolution via product page](#)

*Diagram 1: TEA Chloride's mechanism of action as a potassium channel blocker, leading to a prolonged action potential [1].*

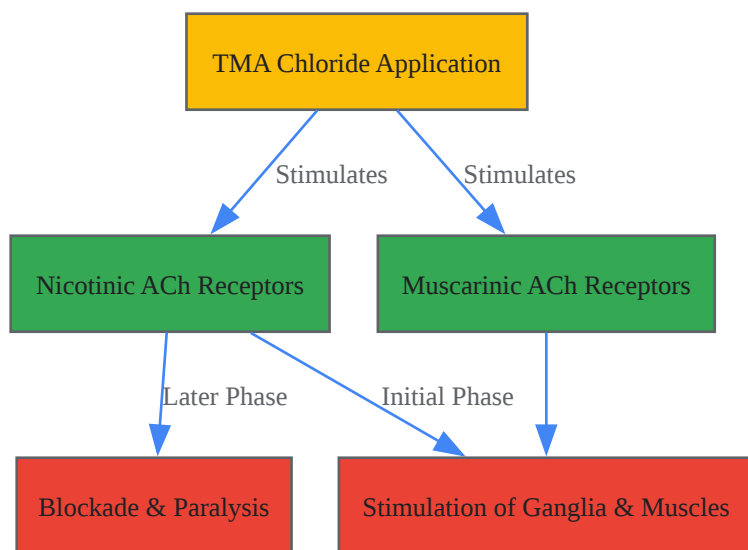

Click to download full resolution via product page

Diagram 2: TMA Chloride's dual-phase cholinomimetic effect, showing initial stimulation followed by blockade [2].

## Key Selection Guide

- For potassium channel research, **Tetraethylammonium (TEA) Chloride** is the standard tool for blocking K<sup>+</sup> currents and studying action potential repolarization.
- For acetylcholine receptor research, **Tetramethylammonium (TMA) Chloride** is more appropriate as a direct receptor agonist.
- In toxicology, note that TMA is a naturally occurring toxin with a specific mechanism, while TEA's toxicity is related to its disruption of electrical signaling.

### Need Custom Synthesis?

Email: [info@smolecule.com](mailto:info@smolecule.com) or Request Quote Online.

## References

1. Tetramethylammonium Chloride - an overview [sciencedirect.com]
2. Tetramethylammonium [en.wikipedia.org]

3. Tetraethylammonium and tetrodotoxin: effects on cochlear ... [pubmed.ncbi.nlm.nih.gov]
4. Tetramethylammonium chloride [en.wikipedia.org]

To cite this document: Smolecule. [Tetraethylammonium chloride vs tetramethylammonium chloride effects]. Smolecule, [2026]. [Online PDF]. Available at:

[<https://www.smolecule.com/products/b566236#tetraethylammonium-chloride-vs-tetramethylammonium-chloride-effects>]

---

### Disclaimer & Data Validity:

The information provided in this document is for Research Use Only (RUO) and is strictly not intended for diagnostic or therapeutic procedures. While Smolecule strives to provide accurate protocols, we make no warranties, express or implied, regarding the fitness of this product for every specific experimental setup.

**Technical Support:** The protocols provided are for reference purposes. Unsure if this reagent suits your experiment? [Contact our Ph.D. Support Team for a compatibility check]

**Need Industrial/Bulk Grade?** Request Custom Synthesis Quote

## Smolecule

Your Ultimate Destination for Small-Molecule (aka. smolecule) Compounds, Empowering Innovative Research Solutions Beyond Boundaries.

### Contact

**Address:** Ontario, CA 91761, United States  
**Phone:** (512) 262-9938  
**Email:** [info@smolecule.com](mailto:info@smolecule.com)  
**Web:** [www.smolecule.com](http://www.smolecule.com)