

Technical Whitepaper: The Role of HMBOA D-glucoside in Plant Defense Mechanisms

Author: Smolecule Technical Support Team. Date: February 2026

Compound Focus: HMBOA D-glucoside

CAS No.: 17622-26-3

Cat. No.: S565528

[Get Quote](#)

Executive Summary

HMBOA D-glucoside represents a significant **benzoxazinoid compound** within the sophisticated chemical defense arsenal of cereal crops, particularly maize and related grasses. This comprehensive review examines the **chemical properties**, **biosynthetic pathways**, **ecological functions**, and **molecular mechanisms** of **HMBOA D-glucoside** in plant protection. As a storage form of the more biologically active aglucone, **HMBOA D-glucoside** functions within a **two-component defense system** that is spatially separated within plant tissues and rapidly activated upon herbivore attack or pathogen challenge. The compound demonstrates **broad-spectrum bioactivity** against insects, nematodes, and microbial pathogens through multiple modes of action, including direct toxicity, antifeedant properties, and potential signaling functions. Recent advances in **metabolomic technologies** have enhanced our understanding of **HMBOA D-glucoside's** role in plant-insect interactions and its potential applications in sustainable agriculture and pharmaceutical development. This whitepaper provides researchers with detailed experimental protocols, structural analyses, and mechanistic insights to support further investigation into this versatile plant defense metabolite.

Introduction to Benzoxazinoids in Plant Defense

Chemical Defense Systems in Plants

Plants have evolved sophisticated multi-layered immune systems comprising both constitutive and inducible defenses to protect against biotic stressors. **Secondary metabolites** play a crucial role in these defense mechanisms, with **benzoxazinoids (BXDs)** representing a particularly important class of **defense chemicals** in grasses. These **indole-derived compounds** are characterized by a 2-hydroxy-2H-1,4-benzoxazin-3(4H)-one skeleton and their derivatives, displaying a wide spectrum of antifeedant, insecticidal, antimicrobial, and allelopathic activities [1]. BXDs are strategically distributed throughout plant tissues and function as part of a sophisticated chemical defense system that can be rapidly activated upon tissue damage. The compartmentalization of stable glucosylated forms and their activating enzymes represents an efficient two-component defense strategy that minimizes autotoxicity while maximizing defensive potential upon herbivory or pathogen attack [1].

Distribution Across Plant Species

BXDs are widely distributed in grasses (**Poaceae**), including economically important cereal crops such as **maize, wheat, and rye**, though they are notably absent in rice, oat, sorghum, and cultivated barley [1]. These compounds have also been identified in select dicot species within the Acanthaceae, Ranunculaceae, Plantaginaceae, and Lamiaceae families [1]. The occurrence of specific BXDs varies between plant species and cultivars, with differences in composition and concentration influencing their effectiveness against various pests and pathogens. The **phylogenetic distribution** of BXDs suggests an evolutionary history involving gene duplication and functional diversification, making them a fascinating subject for studying the evolution of plant chemical defenses [1].

Chemical Profile of HMBOA D-glucoside

Structure and Properties

HMBOA D-glucoside (2-hydroxy-7-methoxy-1,4-benzoxazin-3-one glucoside) is a **glucosylated benzoxazinoid** that serves as a stable storage form within the plant's defensive repertoire. The compound consists of a **benzoxazinone aglycone** conjugated with a **D-glucose molecule** at the 2-hydroxy position, rendering it less reactive than its corresponding aglucone. The methoxy group at the 7-position distinguishes HMBOA from other benzoxazinoids and influences its biological activity and chemical reactivity. In maize,

HMBOA D-glucoside has been detected in leaf vacuoles and waxes on the surface of maize whorls, where it appears to remain stable in the waxy layer [1]. The structural characteristics of **HMBOA D-glucoside** contribute to its relative stability while allowing rapid conversion to the more biologically active aglucone upon tissue damage.

Biosynthetic Pathway

The biosynthesis of **HMBOA D-glucoside** follows the general benzoxazinoid pathway, which has been primarily characterized in maize. The pathway begins with the conversion of **indole-3-glycerol phosphate** to **indole** by BX1 in the chloroplasts. Subsequent steps involve four cytochrome P450-dependent monooxygenases (BX2-BX5) that sequentially introduce oxygen atoms to form **DIBOA aglucone**. This intermediate is then glucosylated by UDP-glucosyltransferases (BX8 and BX9) to produce **DIBOA-Glc**, which serves as a branch point in the pathway. **HMBOA-Glc** is formed from **DIMBOA-Glc** via an O-methylation reaction catalyzed by a group of three homologous O-methyltransferases (BX10, BX11, and BX12) [1]. The stable glucosylated forms are subsequently transported and stored in the vacuole, spatially separated from the β -glucosidases that activate them upon tissue damage.

Table 1: Key Enzymes in **HMBOA D-glucoside** Biosynthesis

Enzyme	Function	Location	Note
BX1	Converts indole-3-glycerol phosphate to indole	Chloroplasts	Homolog of α -subunit of tryptophan synthase
BX2-BX5	Cytochrome P450-dependent monooxygenases	Endoplasmic reticulum	Introduce four oxygen atoms to form DIBOA
BX8/BX9	UDP-glucosyltransferases	Cytoplasm	Glucosylate DIBOA aglucone to DIBOA-Glc
BX10-BX12	O-methyltransferases	Cytoplasm	Convert DIMBOA-Glc to HDMBOA-Glc

The diagram below illustrates the biosynthetic pathway and compartmentalization of **HMBOA D-glucoside**:

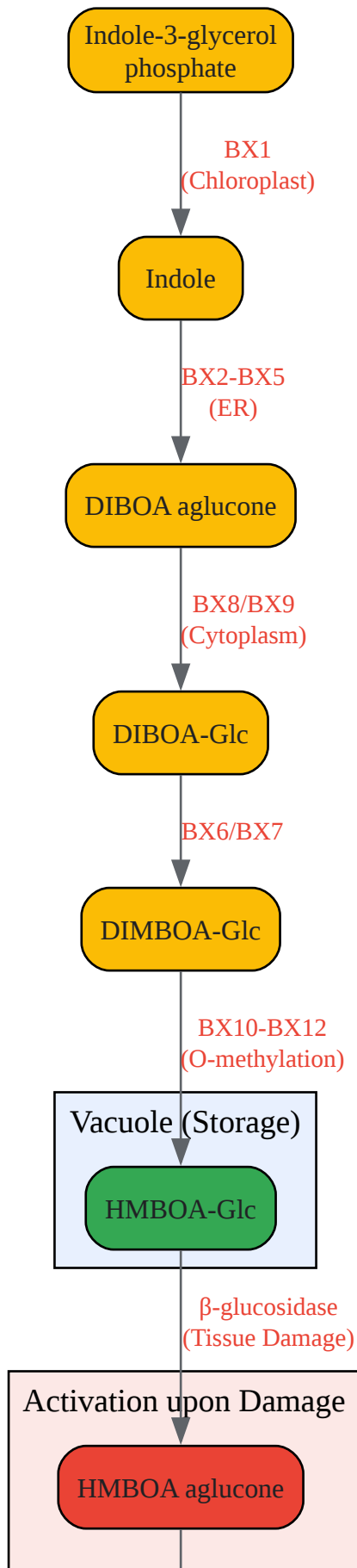

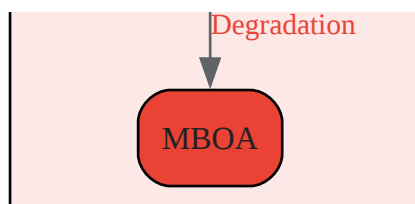

[Click to download full resolution via product page](#)

Biosynthesis and Activation Mechanisms

Spatial Organization of Biosynthesis

The biosynthesis of **HMBOA D-glucoside** involves a carefully orchestrated **subcellular compartmentalization** that prevents autotoxicity while allowing rapid activation upon demand. The initial steps occur in the chloroplasts and endoplasmic reticulum, where the core benzoxazinoid skeleton is assembled. The resulting **aglucone intermediates** are subsequently glucosylated in the cytoplasm by UDP-glucosyltransferases, producing the stable **glucoside forms** [1]. These glucosylated derivatives are then transported and stored in the **vacuole**, where they accumulate without harming the plant cell. This spatial separation is crucial for the plant's defense strategy, as it allows for the storage of large quantities of potentially toxic compounds in an inert form that can be rapidly mobilized when needed.

Two-Component Activation System

The activation of **HMBOA D-glucoside** follows a **two-component system** that is characteristic of many plant defense compounds. When plant tissues are damaged by herbivores or pathogens, the **cellular compartmentalization** breaks down, allowing the stable glucosides to come into contact with **β -glucosidases** that are localized in plastids, cytoplasm, and cell walls [1]. These enzymes catalyze the hydrolysis of the glucose moiety, releasing the biologically active **aglucone**. In the case of **HMBOA D-glucoside**, this reaction yields **HMBOA aglucone**, which can further degrade to **MBOA** (6-methoxybenzoxazolin-2-one) and other derivatives. The activation process is remarkably efficient, converting the inert storage form into bioactive compounds within minutes of tissue damage, providing a rapid response to herbivore attack or pathogen challenge.

Table 2: Components of the **HMBOA D-glucoside** Activation System

Component	Location	Function	Note
HMBOA D-glucoside	Vacuole	Stable storage form	Accumulates without autotoxicity
β -glucosidases	Plastids, cytoplasm, cell walls	Activation enzyme	Spatially separated from substrate
HMBOA aglucone	Released upon damage	Bioactive form	Direct defense compound
MBOA	Degradation product	Stable defensive compound	Further degradation product

Defense Mechanisms and Biological Activities

Direct Antibiotic Effects

HMBOA D-glucoside and its activated forms exhibit **broad-spectrum bioactivity** against various plant pests and pathogens. The compound demonstrates significant **nematostatic and nematocidal activities** against plant-parasitic nematodes, either causing reversible paralysis or irreversible death depending on concentration and exposure duration [2]. Against insect herbivores, HMBOA derivatives function through multiple mechanisms including **antifeedant effects, toxicity, and digestibility reduction**. The effectiveness varies based on the feeding guild of the herbivore, with chewing insects, piercing-sucking insects, and root herbivores exhibiting different susceptibility profiles [1]. The antimicrobial activity of HMBOA derivatives provides additional protection against fungal and bacterial pathogens, making benzoxazinoids a comprehensive chemical defense system for the producing plants.

Defense Modulation and Signaling Functions

Beyond direct toxicity, **HMBOA D-glucoside** may participate in **defense signaling** and **priming mechanisms**. Plants treated with benzoxazinoids can exhibit enhanced readiness to activate defense

responses upon subsequent challenge, a phenomenon known as **priming**. Additionally, benzoxazinoids exuded into the rhizosphere can influence the soil microbiome, potentially attracting beneficial microorganisms that contribute to plant defense [1]. For instance, benzoxazinoids in root exudates of maize have been shown to attract **Pseudomonas putida** to the rhizosphere, potentially enhancing plant growth and indirect defense [3]. These multifaceted functions highlight the ecological complexity of **HMBOA D-glucoside** in plant-environment interactions, extending beyond simple toxicity to include modulation of the plant's defensive state and its associated microbiome.

Research Methodologies and Analytical Techniques

Metabolomic Analysis Approaches

Advanced **metabolomic technologies** have revolutionized the study of **HMBOA D-glucoside** and related benzoxazinoids. **Liquid chromatography-mass spectrometry (LC-MS)** has emerged as the primary analytical method, with both **untargeted and widely-targeted metabolomic approaches** being employed to profile these compounds in plant tissues [4]. The identification of **HMBOA D-glucoside** typically involves **fragmentation pattern analysis**, where characteristic neutral losses corresponding to CO₂ (44 Da), CH₂O₂ (46 Da), CO (28 Da), and 2CO (56 Da) help confirm the compound's identity [4]. For improved separation of benzoxazinoid glucosides, **biphenyl HPLC columns** have demonstrated superior performance compared to conventional C18 columns, allowing resolution of structurally similar compounds like DIMBOA-glc and DIM2BOA-glc [3]. This chromatographic advancement enables more accurate quantification and eliminates the need for relative quantification based solely on mass spectrometry.

Experimental Bioassays

Bioactivity assessment of **HMBOA D-glucoside** involves standardized laboratory bioassays that evaluate its effects on target organisms. For nematodes, the most common assay involves dissolving the compound of interest in water at biologically relevant concentrations and incubating nematodes in this solution for several hours or days [2]. The response is categorized as **nematistatic** (reversible paralysis) or **nematicidal** (irreversible paralysis or death) based on recovery tests after transferring nematodes to clean water. For insect bioassays, researchers employ **feeding deterrence assays**, **growth inhibition studies**, and **metabolic**

stability assessments to determine the compound's efficacy and mode of action [1]. These bioassays are typically conducted with purified compounds or plant extracts containing known concentrations of **HMBOA D-glucoside** and related benzoxazinoids to establish dose-response relationships and determine ecological relevance.

The diagram below illustrates the experimental workflow for studying **HMBOA D-glucoside**:

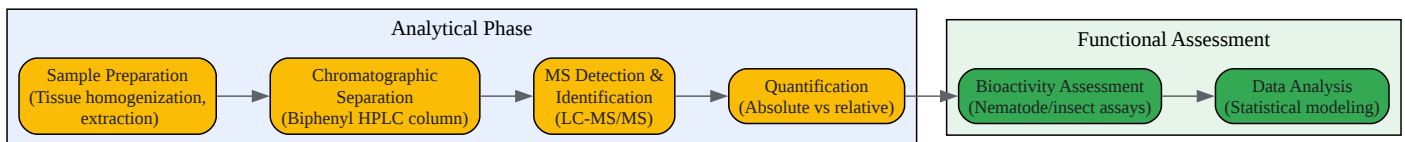

[Click to download full resolution via product page](#)

Applications and Future Research Directions

Agricultural Applications

The understanding of **HMBOA D-glucoside**'s role in plant defense opens promising avenues for **sustainable agriculture**. Breeding programs can leverage natural variation in benzoxazinoid content and composition to develop crop cultivars with enhanced inherent resistance to pests and diseases [2]. The **genetic engineering** of benzoxazinoid pathways into non-producing crops represents another potential application, though this requires careful consideration of ecological impacts and potential trade-offs with growth and yield. Additionally, **cultural practices** that optimize benzoxazinoid production, such as specific fertilization regimes or companion planting, could enhance crop resilience without external inputs. The application of benzoxazinoid-containing extracts as natural pesticides also shows promise for organic farming systems, providing effective pest control while minimizing environmental impact and resistance development compared to synthetic pesticides.

Pharmacological Potential

While traditionally studied for their roles in plant defense, benzoxazinoids like **HMBOA D-glucoside** have attracted interest for their potential **health-protecting properties** in humans [3]. Research has begun to explore the **absorption and metabolic fate** of bioactive dietary benzoxazinoids in humans, revealing their potential bioavailability and biological activity [3]. These compounds may contribute to the health benefits associated with whole-grain consumption, though much remains to be learned about their mechanisms of action in mammalian systems. Future research should focus on elucidating the **molecular targets** of benzoxazinoids in human physiology, assessing their **therapeutic potential**, and establishing safe intake levels. The dual significance of **HMBOA D-glucoside** in both plant ecology and human health makes it a compelling subject for interdisciplinary research spanning plant science, chemistry, and biomedical fields.

Conclusion

Need Custom Synthesis?

Email: info@smolecule.com or Request Quote Online.

References

1. and herbivore counter- Plant : benzoxazinoids and... defense defense [link.springer.com]
2. Frontiers | A Phytochemical Perspective on Plant Against... Defense [frontiersin.org]
3. (PDF) Biphenyl Columns Provide Good Separation of the Glucosides ... [academia.edu]
4. Metabolomic Analysis Reveals the Diversity of Defense Metabolites in... [pmc.ncbi.nlm.nih.gov]

To cite this document: Smolecule. [Technical Whitepaper: The Role of HMBOA D-glucoside in Plant Defense Mechanisms]. Smolecule, [2026]. [Online PDF]. Available at:

[<https://www.smolecule.com/products/b565528#role-of-hmboa-d-glucoside-in-plant-defense>]

Disclaimer & Data Validity:

The information provided in this document is for Research Use Only (RUO) and is strictly not intended for diagnostic or therapeutic procedures. While Smolecule strives to provide accurate protocols, we make no warranties, express or implied, regarding the fitness of this product for every specific experimental setup.

Technical Support: The protocols provided are for reference purposes. Unsure if this reagent suits your experiment? [Contact our Ph.D. Support Team for a compatibility check]

Need Industrial/Bulk Grade? Request Custom Synthesis Quote

Smolecule

Your Ultimate Destination for Small-Molecule (aka. smolecule) Compounds, Empowering Innovative Research Solutions Beyond Boundaries.

Contact

Address: Ontario, CA 91761, United States

Phone: (512) 262-9938

Email: info@smolecule.com

Web: www.smolecule.com