

tirabrutinib histological verification tumor eradication

Author: Smolecule Technical Support Team. **Date:** February 2026

Compound Focus: Tirabrutinib

CAS No.: 1351636-18-4

Cat. No.: S545415

Get Quote

Histological Evidence for Tumor Eradication

A key study provides direct pathological verification of **tirabrutinib**'s efficacy in a human patient with relapsed/refractory PCNSL [1] [2].

- **Patient Case:** A 64-year-old woman with recurrent PCNSL was treated with 480 mg **tirabrutinib** once daily in a phase I/II clinical trial [2].
- **Radiological Response:** MRI scans showed the complete disappearance of a cerebellar lesion one month after starting treatment [2].
- **Histological Verification:** The patient died 43 days after treatment initiation due to an adverse event (suspected pneumocystis pneumonia and interstitial pneumonia). A subsequent autopsy of the entire brain found **no viable tumor cells** at the site of the original cerebellar lesion, confirming complete pathological eradication of the tumor cells [1] [2].

This case offers the first reported histological proof in humans that **tirabrutinib** can achieve complete tumor cell obliteration in PCNSL [2].

Clinical Efficacy Data from Meta-Analysis

A 2025 meta-analysis of seven clinical trials provides a broader view of **tirabrutinib**'s performance across several B-cell malignancies, showing strong overall efficacy [3]. The table below summarizes the pooled

efficacy outcomes.

Efficacy Outcome	Pooled Rate (Range)	Key Findings by Cancer Type
Overall Response Rate (ORR)	72.5% [3]	Consistent high activity across subtypes [3]
Complete Response (CR) Rate	18.6% [3]	PCNSL studies reported CR rates of 34% [2]
Partial Response (PR) Rate	41.1% [3]	Major contributor to overall response [3]
Median Progression-Free Survival (PFS)	Not pooled	Highest in CLL (38.5 months) [3]

Mechanism of Action and Experimental Analysis

Tirabrutinib is a second-generation, potent, irreversible, and **highly selective Bruton's tyrosine kinase (BTK) inhibitor** [3] [4]. Its anti-tumor mechanism has been investigated using phosphoproteomic and transcriptomic analyses in activated B-cell-like diffuse large B-cell lymphoma (ABC-DLBCL) models [4].

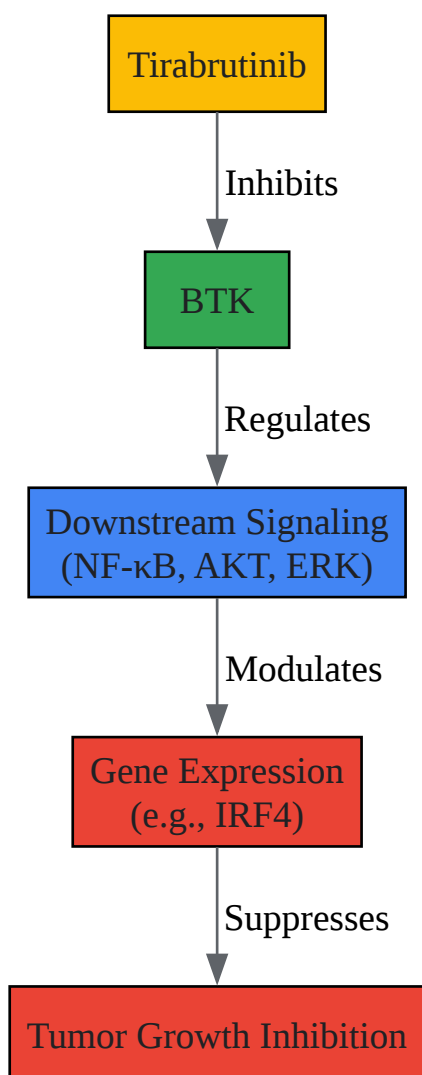

[Click to download full resolution via product page](#)

The mechanistic workflow shows that **tirabrutinib** binds BTK, disrupting survival signals and gene expression to suppress tumors [4]. Key experimental findings include:

- **High Selectivity:** Biochemical kinase profiling demonstrated that **tirabrutinib** has a superior selectivity profile compared to the first-generation BTK inhibitor ibrutinib, which may contribute to an improved safety profile [4].
- **Pathway Inhibition:** In ABC-DLBCL cell lines, treatment with **tirabrutinib** led to the downregulation of key oncogenic signaling pathways, including **ERK and AKT** [4].
- **Gene Expression Changes:** Transcriptomic analysis in a xenograft model revealed that **tirabrutinib** treatment decreased gene expression signatures related to **IRF4**, a transcription factor critical for the survival of certain B-cell lymphomas [4].

Safety and Adverse Events

The safety profile of **tirabrutinib** is generally manageable, though certain adverse events (AEs) require attention [3] [5].

- **Common AEs:** The most common adverse event is **neutropenia** (both all grades and grade ≥ 3). There is also a reported high incidence of skin-related adverse events [3].
- **Serious AEs:** In the PCNSL studies, grade ≥ 3 adverse events occurred in 52.3% of patients. Serious adverse events, including one treatment-related death due to pneumocystis jirovecii pneumonia and interstitial lung disease, have been reported, highlighting the need for vigilant monitoring and prophylaxis [5] [1].

Need Custom Synthesis?

Email: info@smolecule.com or Request Quote Online.

References

1. Histological verification of the treatment effect of tirabrutinib ... [pmc.ncbi.nlm.nih.gov]
2. Histological verification of the treatment effect of tirabrutinib for ... [ehonline.biomedcentral.com]
3. Efficacy and safety of tirabrutinib monotherapy in relapsed or ... [pmc.ncbi.nlm.nih.gov]
4. Investigation of the anti-tumor mechanism of tirabrutinib, a ... [journals.plos.org]
5. Three-year follow-up analysis of phase 1/2 study on ... [pmc.ncbi.nlm.nih.gov]

To cite this document: Smolecule. [tirabrutinib histological verification tumor eradication]. Smolecule, [2026]. [Online PDF]. Available at: [<https://www.smolecule.com/products/b545415#tirabrutinib-histological-verification-tumor-eradication>]

Disclaimer & Data Validity:

The information provided in this document is for Research Use Only (RUO) and is strictly not intended for diagnostic or therapeutic procedures. While Smolecule strives to provide accurate protocols, we make no

warranties, express or implied, regarding the fitness of this product for every specific experimental setup.

Technical Support: The protocols provided are for reference purposes. Unsure if this reagent suits your experiment? [Contact our Ph.D. Support Team for a compatibility check]

Need Industrial/Bulk Grade? Request Custom Synthesis Quote

Smolecule

Your Ultimate Destination for Small-Molecule (aka. smolecule) Compounds, Empowering Innovative Research Solutions Beyond Boundaries.

Contact

Address: Ontario, CA 91761, United States

Phone: (512) 262-9938

Email: info@smolecule.com

Web: www.smolecule.com