

# specificity of Potasan detection platforms

**Author:** Smolecule Technical Support Team. **Date:** February 2026

## Compound Focus: Potasan

CAS No.: 299-45-6

Cat. No.: S540028

Get Quote

## Technology Comparison at a Glance

The table below summarizes the core operating principles and key performance metrics of several platforms developed for potassium ion ( $K^+$ ) detection.

Detection Platform	Working Principle	Sensitivity	Dynamic Range	Key Experimental Findings
<b>a-IGZO FET Sensor [1]</b>	Potentiometric; Resistive coupling in a coplanar-gate FET with $K^+$ -selective membrane	51.9 mV/dec (Basic); <b>597.1 mV/dec</b> (Self-amplified)	Not explicitly stated	High selectivity: <6.6 mV/dec sensitivity for $Na^+$ , $Ca^{2+}$ , and $H^+$ . Stable, reliable short/long-term detection. [1]
<b>Graphene/PEDOT ISE [2]</b>	Potentiometric; In-situ polymerization of PEDOT on graphene electrode with $K^+$ -selective membrane	Near-Nernstian	1–40 mM	Excellent selectivity against $Na^+$ , glucose, dopamine, urea. Good repeatability, reproducibility, long-term stability. [2]
<b>Smartphone Turbidity [3]</b>	Optical turbidity; Precipitation of $K^+$ with Na-TPB and	Accuracy: $\pm$ 0.18 mM	1.5–7.5 mM	Correlation with ISE and AAS. Precision: $\pm$ 0.27 mM. Low-cost,

Detection Platform	Working Principle	Sensitivity	Dynamic Range	Key Experimental Findings
	smartphone image analysis			point-of-care potential. [3]
<b>PEDOT:PSS OECT</b> [4]	Potentiometric; Organic Electrochemical Transistor with ion-selective membrane	Statistically optimized via membrane composition	1–100 mM	Multiplexed real-time sensing of Na <sup>+</sup> and K <sup>+</sup> . Sensitivity increases with reduced membrane thickness (at the cost of selectivity). [4]
<b>Raman Spectroscopy</b> [5]	Raman Scattering; Precipitation with sodium cobaltinitrite on a hydrophobic (PTFE) surface	Achieved detection in human serum	Not explicitly stated	Enabled quantitative detection in serum without sample pretreatment via hydrophobic concentrating effect. [5]

## Detailed Experimental Protocols

For reproducibility, here are the detailed methodologies cited in the research for key platforms.

### High-Performance a-IGZO FET Biosensor

- **Device Fabrication:** The transducer unit is an amorphous Indium Gallium Zinc Oxide (a-IGZO) Thin-Film Transistor (TFT) with a **coplanar-gate structure** (Control Gate CG, Sensing Gate SG, Floating Gate FG) fabricated on a glass substrate. The gates are connected via resistive layers (RCG, RSG) to enable self-amplification. [1]
- **Sensing Unit:** An extended gate (EG) is functionalized with a **potassium-selective membrane** (likely containing valinomycin). [1] [6]
- **Measurement Protocol:** The platform is connected to a semiconductor parameter analyzer. Transfer characteristic curves (ID-VG) are measured while the EG is immersed in KCl solutions of varying concentrations. The **shift in threshold voltage (VTH)** is recorded as the sensor's response. Sensitivity is calculated from the voltage shift per decade change in K<sup>+</sup> concentration. Selectivity is tested by repeating the process with NaCl, CaCl<sub>2</sub>, and pH buffer solutions. [1]

## Graphene-Based Electrochemical Sensor

- **Electrode Modification:** A glassy carbon electrode is first modified with graphene. The **PEDOT** layer is then synthesized through **in-situ electrochemical polymerization** of the EDOT monomer on the graphene surface. Finally, a **potassium ion-selective membrane** (PEDOT) is applied to form the working electrode. [2]
- **Measurement & Characterization:** The sensor's physical morphology is characterized by **Scanning Electron Microscopy (SEM)**. Its electrochemical properties, including conductivity and potentiometric response, are measured using an electrochemical workstation. The sensor is tested in standard  $K^+$  solutions to generate a calibration curve and in solutions containing potential interferents to confirm selectivity. [2]

## Smartphone-Enabled Turbidity Method

- **Sample Preparation (Calibration Curve):**
  - **Create  $K^+$ -free Plasma:** Blood plasma is mixed with sodium tetraphenylborate (Na-TPB) to precipitate out all endogenous  $K^+$ . The precipitate is removed via centrifugation, and the process is repeated to ensure complete  $K^+$  removal. [3]
  - **Spike Standards:** The  $K^+$ -free plasma is spiked with known concentrations of KCl (e.g., 1.5–7.5 mM) and mixed with a fixed amount of Na-TPB to form a turbid solution of K-TPB precipitate. [3]
- **Optical Measurement:**
  - A smartphone is placed in a custom darkbox with a consistent LED light source. [3]
  - Images of the turbid samples are captured by the smartphone camera. [3]
  - A custom image-processing algorithm converts the image from RGB to **HSV color space**. The **Value (V) component**, which correlates with light intensity/turbidity, is used to construct the calibration curve against  $K^+$  concentration. [3]

## Operational Principles and Workflows

The following diagrams illustrate the core working principles and experimental workflows of the discussed platforms.

## Field-Effect Transistor (FET) Based Sensing

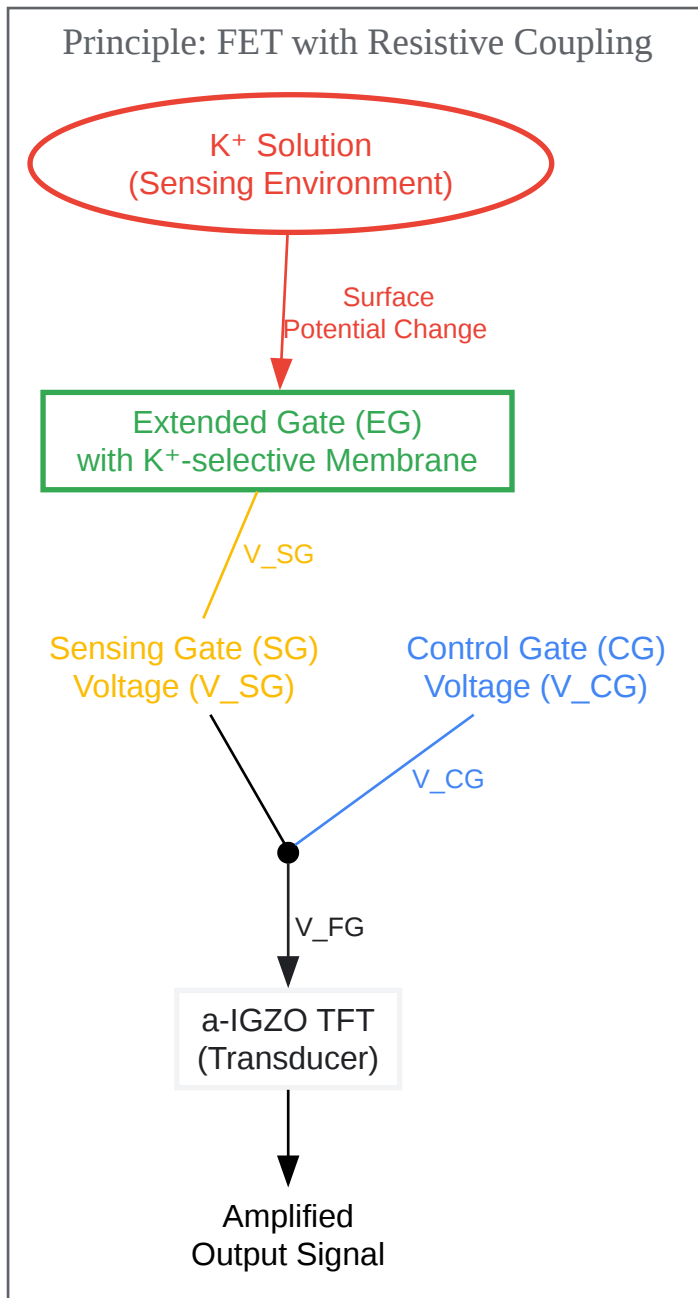

[Click to download full resolution via product page](#)

## Smartphone-based Turbidity Workflow

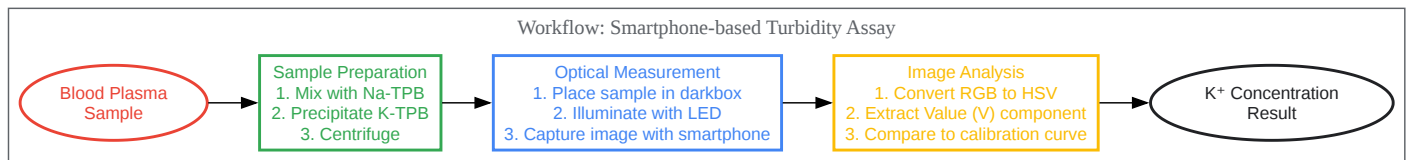

[Click to download full resolution via product page](#)

## Interpretation of Key Metrics and Trends

The data reveals several important trends for researchers evaluating these platforms:

- **Overcoming the Nernstian Limit:** The **a-IGZO FET sensor** demonstrates a key innovation by using **resistive coupling** to achieve a sensitivity of **597.1 mV/dec**, far exceeding the traditional Nernstian limit ( $\sim 59$  mV/dec at room temperature). This self-amplification is crucial for detecting very small concentration changes. [1]
- **The Selectivity-Reliability Trade-off:** High **selectivity**, often achieved using the ionophore **valinomycin** [6] [2], is a hallmark of robust clinical sensors. Furthermore, research on OECTs highlights a critical engineering trade-off: optimizing membrane composition and thickness can increase **sensitivity** but may come at the cost of reduced **selectivity**. [4]
- **The Push Toward Point-of-Care (PoC):** Technologies like the **smartphone-based turbidity** assay and **graphene/PEDOT ISE** are significant for their potential in decentralized testing. They focus on using low-cost materials and common devices to create accurate, portable platforms that do not require complex lab equipment. [2] [3]

## Critical Considerations for Platform Selection

When selecting a potassium detection platform for your specific application, please consider these factors:

- **Sample Type:** The **smartphone turbidity method** and **Raman spectroscopy** protocol were specifically validated using processed **blood plasma**. [3] [5] Other sensors like the **PEDOT:PSS OECT** are well-suited for **sweat** analysis. [4]
- **Data Completeness:** Please note that some performance data is missing from the literature. For instance, the dynamic range for the a-IGZO FET sensor and the exact sensitivity values for the PEDOT:PSS OECT were not fully detailed in the available articles. [1] [4]

- **Technology Maturity:** While these platforms show high research promise, many are still in the development stage. Widespread clinical adoption will require further validation, regulatory approval, and development of standardized commercial products. [6] [7]

### **Need Custom Synthesis?**

Email: [info@smolecule.com](mailto:info@smolecule.com) or [Request Quote Online](#).

## References

1. High-Performance Potassium-Selective Biosensor Platform ... [pmc.ncbi.nlm.nih.gov]
2. A graphene-based electrochemical detection platform for ... [sciencedirect.com]
3. Smartphone-Enabled Quantification of Potassium in Blood ... [pmc.ncbi.nlm.nih.gov]
4. Real-time and multiplexed detection of sodium and ... [sciencedirect.com]
5. Detection of physiological potassium ions level in human ... [sciencedirect.com]
6. Point-of-care and self-testing for potassium: recent advances [pmc.ncbi.nlm.nih.gov]
7. Global Home Potassium Monitoring Devices Market 2025 [custommarketinsights.com]

To cite this document: Smolecule. [specificity of Potasan detection platforms]. Smolecule, [2026]. [Online PDF]. Available at: [<https://www.smolecule.com/products/b540028#specificity-of-potasan-detection-platforms>]

### **Disclaimer & Data Validity:**

The information provided in this document is for Research Use Only (RUO) and is strictly not intended for diagnostic or therapeutic procedures. While Smolecule strives to provide accurate protocols, we make no warranties, express or implied, regarding the fitness of this product for every specific experimental setup.

**Technical Support:** The protocols provided are for reference purposes. Unsure if this reagent suits your experiment? [Contact our Ph.D. Support Team for a compatibility check]

**Need Industrial/Bulk Grade?** Request Custom Synthesis Quote

## Smolecule

Your Ultimate Destination for Small-Molecule (aka. smolecule) Compounds, Empowering Innovative Research Solutions Beyond Boundaries.

### Contact

**Address:** Ontario, CA 91761, United States

**Phone:** (512) 262-9938

**Email:** [info@smolecule.com](mailto:info@smolecule.com)

**Web:** [www.smolecule.com](http://www.smolecule.com)