

Laquinimod Method Validation: Precision & Key Parameters

Author: Smolecule Technical Support Team. Date: February 2026

Compound Focus: Laquinimod

CAS No.: 248281-84-7

Cat. No.: S532492

[Get Quote](#)

The quantitative data below is from a 2006 study that developed and validated two LC-MS/MS methods for determining **laquinimod** in human plasma [1].

Table 1: Key Validation Parameters for Two Laquinimod LC-MS/MS Methods [1]

Parameter	Method 1 (Low Level)	Method 2 (Wide Range)
Dynamic Range	0.4 - 100 nmol/L	0.75 - 15000 nmol/L
Lower Limit of Quantification (LLOQ)	0.4 nmol/L	0.75 nmol/L
Intra-Day Precision (Range)	1.6% - 3.5%	1.6% - 3.5%
Inter-Day Precision (Range)	2.1% - 5.7%	2.1% - 5.7%
Extraction Recovery	90% - 97%	90% - 97%
Sample Preparation	Solid-Phase Extraction (SPE)	Protein Precipitation
Chromatography	Isocratic Elution	Fast Gradient Elution

Detailed Experimental Protocols

The following workflows and specifications are recreated based on the methodologies described in the search results [1].

1. Sample Preparation and Analysis Workflow The core process for both methods involves sample preparation followed by LC-MS/MS analysis. The key difference lies in the extraction technique.

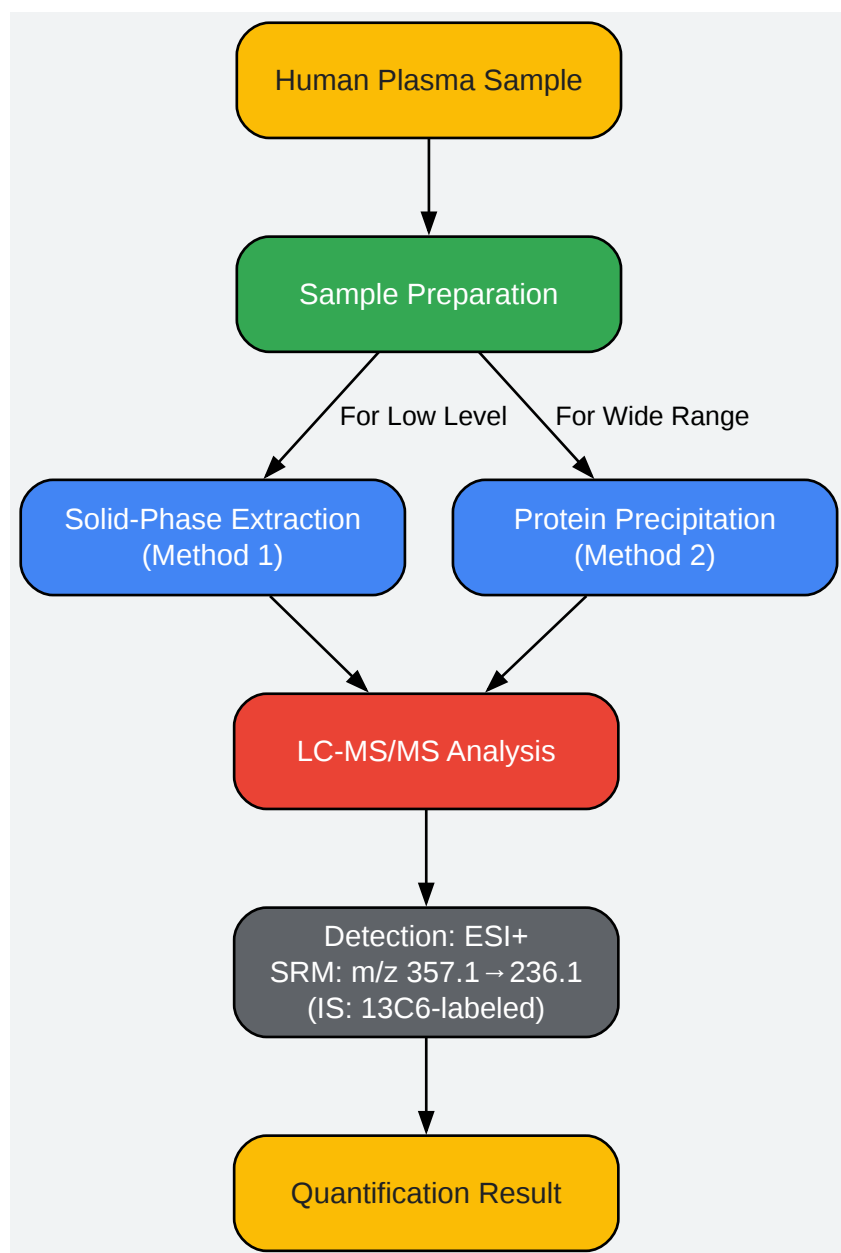

[Click to download full resolution via product page](#)

2. LC-MS/MS Instrument Configuration The analytical core of both methods is consistent, relying on tandem mass spectrometry.

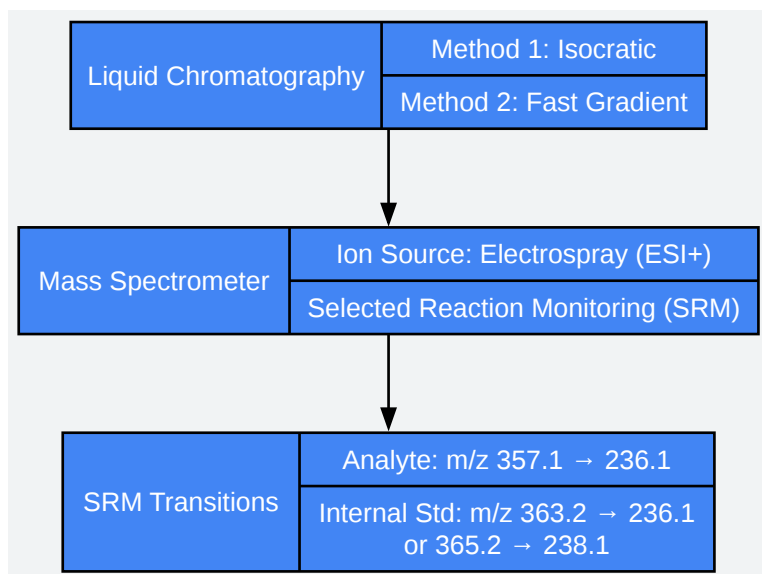

[Click to download full resolution via product page](#)

Frequently Asked Questions

Q1: What are the cited inter-day precision values for the laquinimod assays? The inter-day precision for both LC-MS/MS methods was reported to be between **2.1% and 5.7%** [1]. This data is summarized in Table 1 above.

Q2: My assay precision is outside the validated range. What should I check? While the source does not provide explicit troubleshooting, based on the method description, you should investigate:

- **Internal Standard Performance:** Ensure consistent recovery of the stable isotope ($^{13}\text{C}_6$)-labeled **laquinimod** internal standard, which is critical for assay precision [1].
- **Sample Preparation Consistency:** Check for variability in the solid-phase extraction or protein precipitation steps [1].
- **Chromatography:** Monitor for peak broadening or shifting retention times, which can affect integration and reproducibility [1].

Q3: What is the validated stability of laquinimod in plasma? **Laquinimod** in plasma was found to be stable for at least **3 months when stored at -20°C** [1].

Important Note on Method Applicability

The data provided originates from a **2006** publication [1]. Since the development of **laquinimod** has been discontinued for multiple sclerosis [2], newer or updated clinical assay protocols may not be available. Researchers are advised to use this information as a foundational guide and perform their own comprehensive validation to ensure suitability for current applications.

Need Custom Synthesis?

Email: info@smolecule.com or [Request Quote Online](#).

References

1. development, validation and application of two methods in ... [pubmed.ncbi.nlm.nih.gov]
2. Laquinimod (Nerventra) [mstrust.org.uk]

To cite this document: Smolecule. [Laquinimod Method Validation: Precision & Key Parameters]. Smolecule, [2026]. [Online PDF]. Available at:
[<https://www.smolecule.com/products/b532492#laquinimod-inter-day-precision>]

Disclaimer & Data Validity:

The information provided in this document is for Research Use Only (RUO) and is strictly not intended for diagnostic or therapeutic procedures. While Smolecule strives to provide accurate protocols, we make no warranties, express or implied, regarding the fitness of this product for every specific experimental setup.

Technical Support: The protocols provided are for reference purposes. Unsure if this reagent suits your experiment? [Contact our Ph.D. Support Team for a compatibility check]

Need Industrial/Bulk Grade? [Request Custom Synthesis Quote](#)

Smolecule

Your Ultimate Destination for Small-Molecule (aka. smolecule) Compounds, Empowering Innovative Research Solutions Beyond Boundaries.

Contact

Address: Ontario, CA 91761, United States

Phone: (512) 262-9938

Email: info@smolecule.com

Web: www.smolecule.com