

# Bioresmethrin IRAC classification and resistance

**Author:** Smolecule Technical Support Team. **Date:** February 2026

## Compound Focus: Bioresmethrin

CAS No.: 28434-01-7

Cat. No.: S521289

[Get Quote](#)

## IRAC Classification and Mode of Action

**Bioresmethrin** is part of the pyrethroid class of insecticides. Its classification and neurological action are summarized below.

Property	Classification / Description
IRAC MoA Classification	Group 3A: Sodium channel modulators [1] [2]
Chemical Type	Type I pyrethroid (lacks an alpha-cyano group) [3]
Primary Target	Voltage-gated sodium channels (VGSC) in insect nerve cells [1]
Physiological Effect	Disrupts channel gating, causing prolonged sodium influx, leading to hyperexcitation, convulsions, paralysis, and death [4]

The diagram below illustrates the neurotoxic mechanism of **Bioresmethrin**.

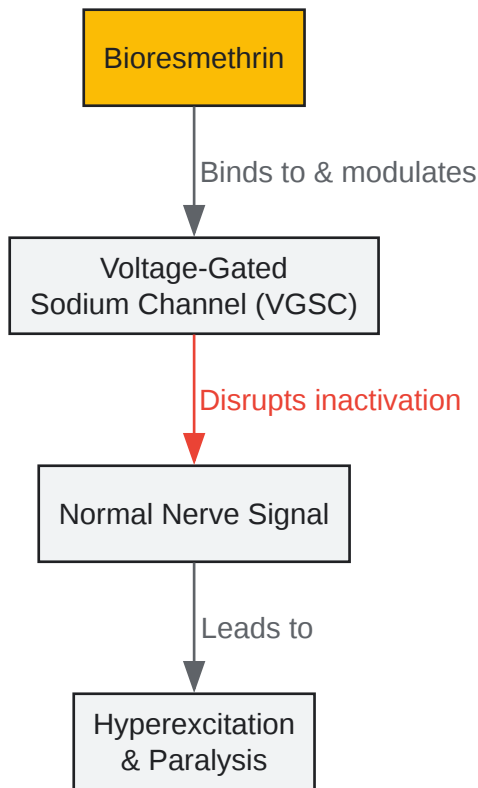

[Click to download full resolution via product page](#)

**Bioresmethrin** mode of action on nerve signaling.

## Resistance Mechanisms and Genetics

Resistance to **bioresmethrin** is a significant concern in pest management. The primary mechanism is target-site resistance, though metabolic resistance also plays a role.

### Target-Site Resistance (kdr mutations)

Mutations in the *Vgsc* gene make it harder for the insecticide to bind effectively [4]. These are known as **knockdown resistance (kdr)** mutations. The table below lists key kdr mutations associated with pyrethroid resistance.

Mutation	Impact / Notes
V1016I	Common, reduces pyrethroid binding affinity [4].
F1534C	Common, confers higher resistance to Type I pyrethroids like bioresmethrin [4].
L982W	Emerging importance, often co-occurs with V1016I for strong resistance [4].
S989P	Often found in combination with V1016I (tri-locus: S989P+V1016I+F1534C) [4].
V410L	Widespread, can occur alone or in combination with other kdr mutations [4].

## Metabolic Resistance

Insects can overproduce detoxification enzymes that break down the insecticide before it reaches its target [4]. The major enzyme families involved are:

- **Cytochrome P450 monooxygenases (P450s)**
- **Carboxylesterases**
- **Glutathione S-transferases (GSTs)**

## Experimental Protocols for Resistance Monitoring

Standardized bioassays and molecular techniques are critical for detecting and characterizing resistance.

### Adult Mosquito Susceptibility Bioassay (WHO Tube Test)

This is the standard method for phenotypically assessing resistance in mosquito populations [5].

- **Principle:** Expose adult female mosquitoes to a diagnostic concentration of insecticide and measure mortality over a set period.
- **Procedure:**
  - **Mosquito Preparation:** Use non-blood-fed, adult female mosquitoes (2-5 days old). A susceptible reference strain should be tested in parallel for comparison.
  - **Exposure:** Transfer 20-25 mosquitoes to a control tube (impregnated with silicone oil only) and an equivalent number to test tubes lined with insecticide-impregnated paper (e.g., at the WHO

diagnostic concentration).

- **Holding:** Keep mosquitoes in the tubes for 1 hour.
- **Transfer and Recovery:** Gently transfer all mosquitoes to holding cups and provide access to sugar solution.
- **Mortality Recording:** Record the number of dead mosquitoes after a 24-hour recovery period. Mortality in the control group must be below a threshold (e.g., <5-10%) for the test to be valid.
- **Data Interpretation:**
  - **Mortality  $\geq$  98%:** Population is susceptible.
  - **Mortality < 90%:** Resistance is confirmed.
  - **Mortality between 90-97%:** Possible resistance; requires further investigation.

## Synergist Assays

These tests help identify the involvement of specific metabolic enzymes.

- **Procedure:** Pre-expose a group of mosquitoes to a synergist (e.g., Piperonyl Butoxide (PBO) which inhibits P450s) for 1 hour, then subject them to the standard bioassay.
- **Interpretation:** If mortality significantly increases in the synergist group compared to the insecticide-only group, it indicates a major role for metabolic resistance (specifically P450s if PBO was used).

## kdr Mutation Genotyping

Molecular techniques are used to identify specific point mutations in the *Vgsc* gene.

- **DNA Extraction:** Extract genomic DNA from individual mosquitoes.
- **PCR Amplification:** Amplify specific regions of the *Vgsc* gene (e.g., domains II and III) using specific primers.
- **Mutation Detection:**
  - **Sequencing:** The gold standard, identifies all known and novel mutations in the amplified region.
  - **Allele-Specific PCR (AS-PCR) or PCR-RFLP:** Faster, cheaper methods for screening known, specific mutations (e.g., V1016I, F1534C).
- **Data Analysis:** Calculate allele frequencies and genotype distributions in the tested population.

The workflow for a comprehensive resistance monitoring study is shown below.

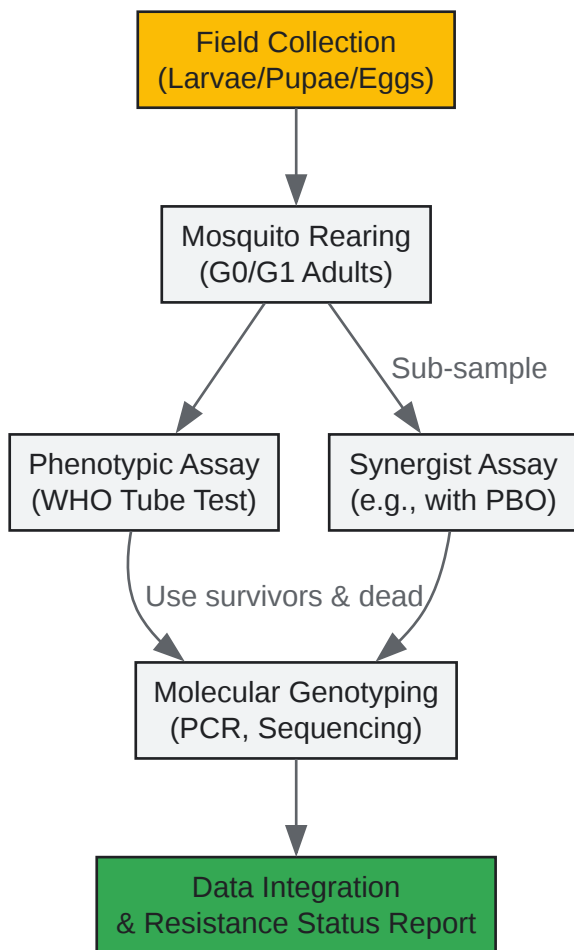

[Click to download full resolution via product page](#)

*Experimental workflow for insecticide resistance monitoring.*

## Implications for Research and Control

- **Resistance Management (IRM): Bioresmethrin** must be strategically rotated or combined with insecticides from different IRAC groups (e.g., Groups 1, 2, 4, 5) to reduce selection pressure [2].
- **Product Development:** The presence of *kdr* mutations can severely compromise the efficacy of pyrethroid-based formulations, necessitating pre-deployment resistance screening.
- **Integrated Vector Management (IVM):** Reliance on chemical control alone is unsustainable. Effective strategies integrate chemical, biological, and environmental methods [4].

**Need Custom Synthesis?**

Email: [info@smolecule.com](mailto:info@smolecule.com) or [Request Quote Online](#).

## References

1. (Ref: FMC 17370) Bioresmethrin [sitem.herts.ac.uk]
2. Mode of Action Classification | Insecticide Resistance Management [irac-online.org]
3. Bioresmethrin (UK PID) [inchem.org]
4. Global distribution and impact of knockdown resistance ...  
[parasitesandvectors.biomedcentral.com]
5. Bioassay tests reveal for the first time pyrethroid resistance in ... [pmc.ncbi.nlm.nih.gov]

To cite this document: Smolecule. [Bioresmethrin IRAC classification and resistance]. Smolecule, [2026]. [Online PDF]. Available at: [<https://www.smolecule.com/products/b521289#bioresmethrin-irac-classification-and-resistance>]

---

### Disclaimer & Data Validity:

The information provided in this document is for Research Use Only (RUO) and is strictly not intended for diagnostic or therapeutic procedures. While Smolecule strives to provide accurate protocols, we make no warranties, express or implied, regarding the fitness of this product for every specific experimental setup.

**Technical Support:** The protocols provided are for reference purposes. Unsure if this reagent suits your experiment? [Contact our Ph.D. Support Team for a compatibility check]

**Need Industrial/Bulk Grade?** [Request Custom Synthesis Quote](#)

## Smolecule

Your Ultimate Destination for Small-Molecule (aka. smolecule) Compounds, Empowering Innovative Research Solutions Beyond Boundaries.

### Contact

**Address:** Ontario, CA 91761, United States

**Phone:** (512) 262-9938

**Email:** [info@smolecule.com](mailto:info@smolecule.com)

**Web:** [www.smolecule.com](http://www.smolecule.com)