

Comprehensive Technical Analysis of Ranolazine's Mechanism of Action: Late Sodium Current Inhibition

Author: Smolecule Technical Support Team. Date: February 2026

Compound Focus: Norazine

CAS No.: 3004-71-5

Cat. No.: S3353457

[Get Quote](#)

Introduction and Molecular Mechanism Overview

Ranolazine represents a **piperazine derivative** with a unique **anti-ischemic mechanism** that distinguishes it from conventional antianginal medications. While traditional anti-ischemic drugs such as β -blockers, calcium channel antagonists, and nitrates primarily reduce myocardial oxygen demand through hemodynamic effects, ranolazine operates through fundamentally different pharmacological principles. Its primary mechanism involves **selective inhibition** of the late sodium current (late I_{Na}) in cardiac myocytes, which addresses the core pathophysiological processes occurring at the cellular level during myocardial ischemia [1].

The pathophysiological sequence begins with myocardial ischemia, which immediately results in **reduced ATP fluxes** and diminished energy supply to key proteins responsible for maintaining intracellular ion homeostasis. Under ischemic conditions, cardiac sodium channels exhibit altered gating behavior characterized by a pronounced late opening that persists for hundreds of milliseconds following depolarization, referred to as the **late sodium current** (late I_{Na}) [1]. This persistent sodium influx represents a major source of **intracellular sodium accumulation** during ischemia, with additional contributions from impaired sodium elimination through the sodium-potassium ATPase and sodium influx through the sodium-

proton exchanger [1]. The consequential sodium overload promotes **reverse mode sodium-calcium exchange**, leading to dangerous calcium accumulation within the cytosol [1].

The following diagram illustrates this central pathological cascade and ranolazine's targeted intervention point:

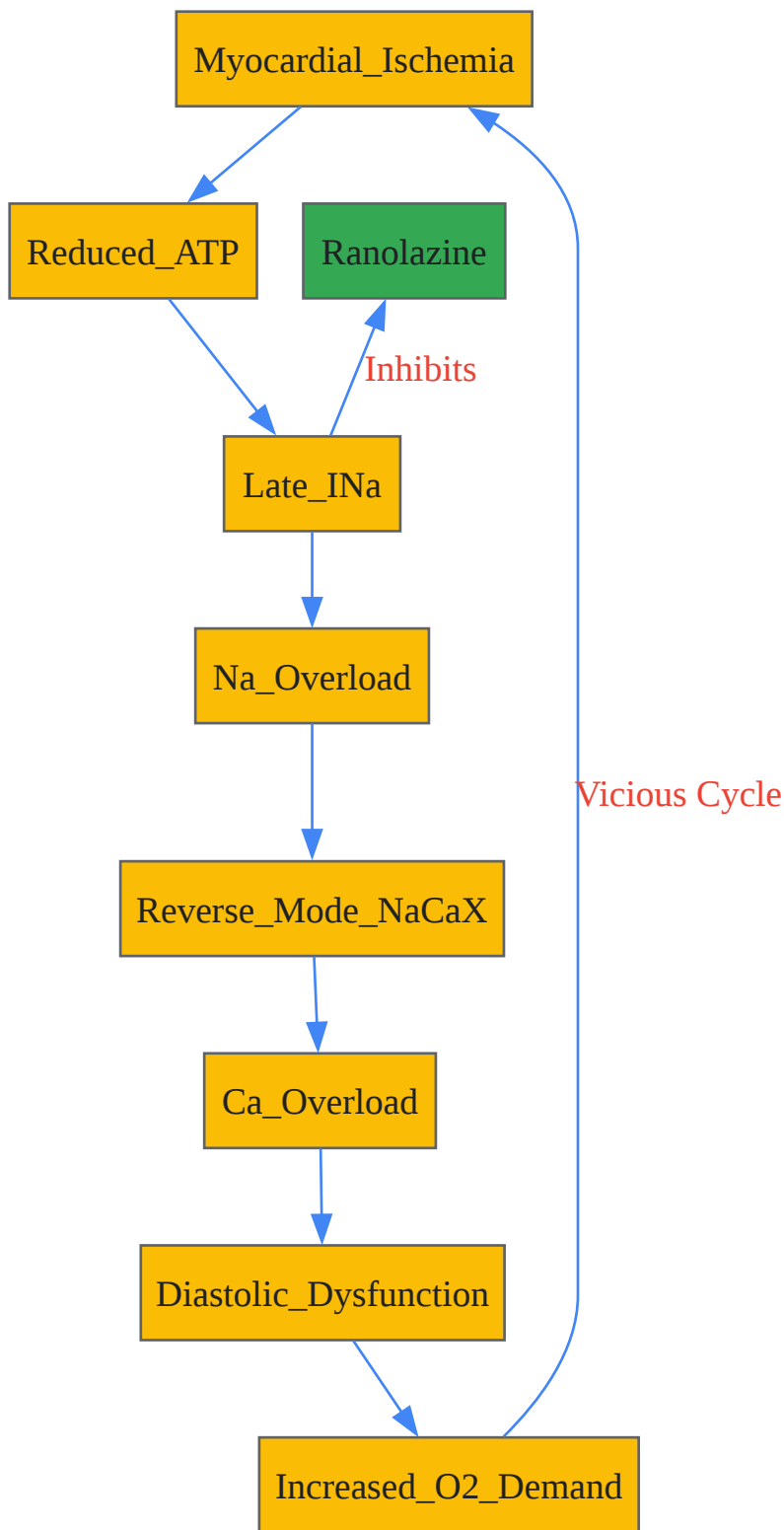

[Click to download full resolution via product page](#)

Figure 1: The ischemic cascade and ranolazine's therapeutic target. Myocardial ischemia triggers sodium and calcium overload through enhanced late INa, creating a vicious cycle. Ranolazine specifically inhibits

late INa to break this pathological process.

This **calcium overload** has particularly detrimental effects on cardiac function, as elevated diastolic calcium levels activate contractile proteins even during diastole, resulting in **impaired ventricular relaxation** and increased diastolic tone. This pathological process creates a vicious cycle wherein diastolic dysfunction increases intramural compression and microcirculatory resistance, further compromising coronary blood flow and exacerbating the original ischemic insult [1]. Ranolazine specifically interrupts this destructive cascade at a pivotal point by potently inhibiting the late INa, thereby preventing sodium overload and its downstream consequences [1].

Structural Basis of Late Sodium Channel Inhibition

High-Resolution Binding Characterization

Recent advances in structural biology have elucidated the precise molecular interactions between ranolazine and its target, the cardiac sodium channel NaV1.5. Cryogenic electron microscopy (cryo-EM) studies have revealed that ranolazine binds within the **central cavity** of the channel's pore module, physically occluding the ion permeation pathway and blocking sodium conductance [2] [3]. The structural analysis demonstrates that ranolazine assumes an **asymmetric binding pose** within the central cavity, forming close contacts with the S6 segments of domains I and IV, with additional distant contacts in domain III [2]. This binding position places the drug directly on the intracellular side of the ion selectivity filter, ideally positioned to block ion permeation while its hydrophobic regions interact with adjacent S6 segments [2].

The molecular interactions between ranolazine and NaV1.5 involve several critical residues that define its unique binding characteristics. In domain IV, ranolazine forms a **T-shaped π - π interaction** (π -teeing) between its lidocaine-like aromatic ring and the side chain of F1762, which represents the canonical residue known to bind the aromatic rings of local anesthetics and antiarrhythmic drugs [2]. Additionally, ranolazine makes contact with small polar residues on the intracellular side of the ion selectivity filter (S1712) and approaches the highly conserved lysine (K1421) that is critical for sodium selectivity [2]. In domain I, ranolazine establishes another T-shaped π - π interaction between the aromatic ring of its atypical methoxyphenoxy group and F403, while also approaching Q372 on the intracellular side of the DI pore

helix [2]. These distinct interactions with DI residues may underlie ranolazine's unique mechanism compared to traditional antiarrhythmic drugs.

Novel Conformational Changes Induced by Ranolazine

Beyond these specific molecular contacts, ranolazine binding induces significant **conformational changes** in the channel structure that contribute to its mechanism of action. Structural analyses have revealed a bend in the DIV-S6 helix resulting from the adoption of a **π -helix conformation** for residues 1765-1769, a transition not observed in previous NaV1.5 structures without the drug bound [2]. This α - π helical transition results in rotational movements of the affected side chains relative to the central cavity, presenting a distinct molecular surface that influences interactions with the fast inactivation gate particle (IFM), DIV/DI fenestration, and activation gate [2]. This drug-induced conformational change may represent an important aspect of ranolazine's mechanism that differentiates it from traditional sodium channel blockers.

The structural basis for ranolazine's **atrial selectivity** has also been investigated through comparative electrophysiological studies. Research has demonstrated that atrial INa activates at command potentials approximately 5.5 mV more negative and inactivates at conditioning potentials about 7 mV more negative than ventricular INa [4]. These intrinsic biophysical differences between atrial and ventricular sodium channels, combined with the distinct binding interactions of ranolazine, contribute to its preferential action in atrial tissue, making it particularly effective for managing atrial arrhythmias while minimizing ventricular proarrhythmic potential [4].

Electrophysiological Effects and Channel Interactions

Quantitative Analysis of Current Inhibition

Ranolazine exhibits a complex electrophysiological profile characterized by state-dependent inhibition of cardiac sodium channels. Whole-cell voltage clamp experiments demonstrate that ranolazine reduces peak sodium current (INa) of NaV1.5 in a **concentration-dependent manner** with an IC₅₀ of 110 μ M when depolarizing pulses are applied at 0.2 Hz, decreasing to 80 μ M with application of 1 Hz repetitive pulses [2]. This **use-dependent behavior** is characteristic of sodium channel-blocking antiarrhythmic drugs and reflects

preferential binding to activated and/or inactivated channel states rather than the resting state [2]. Importantly, ranolazine demonstrates approximately **10-40-fold greater potency** for inhibiting the late sodium current (INaL) compared to the peak sodium current, despite both currents being conducted through the same NaV1.5 channels [2].

The preferential inhibition of late INa produces several significant electrophysiological effects that contribute to ranolazine's therapeutic utility. By reducing the late sodium current, ranolazine indirectly decreases **calcium overload** during ischemic conditions, leading to improved diastolic relaxation and reduced diastolic tension [1]. This effect improves myocardial efficiency and reduces oxygen consumption without negatively affecting hemodynamic parameters. Additionally, ranolazine produces a modest prolongation of action potential duration, reflected clinically as a slight increase in QT interval (typically 2-5 ms) [1]. However, unlike many other QT-prolonging agents, ranolazine does not exhibit heart rate-dependent effects, does not induce early afterdepolarizations, and does not increase dispersion of repolarisation across the left ventricular wall [1]. This safety profile distinguishes it from drugs with higher proarrhythmic potential.

Table 1: Electrophysiological Effects of Ranolazine on Cardiac Ion Currents

Ion Current	Effect	Potency (IC50)	Functional Consequence
Late INa (INaL)	Inhibition	~3-6 $\mu\text{mol/L}$ [5]	Reduced Na ⁺ overload, improved diastolic function
Peak INa	Inhibition	80-110 $\mu\text{mol/L}$ [2]	Use-dependent conduction slowing
IKr	Inhibition	~12 $\mu\text{mol/L}$ [4]	Minimal QT prolongation (2-6 ms)
Fatty Acid Oxidation	Inhibition	Therapeutic concentrations [6]	Shift to more oxygen-efficient glucose metabolism

Atrial-Selective Electrophysiological Actions

Comparative studies in atrial versus ventricular myocytes have revealed important differences in ranolazine's electrophysiological effects that underlie its **atrial-selective action**. Research has demonstrated that atrial INa activates at command potentials approximately 5.5 mV more negative and inactivates at conditioning

potentials about 7 mV more negative than ventricular I_{Na} [4]. These intrinsic biophysical differences, combined with the more depolarized resting membrane potential and shorter action potential duration in atrial cells, result in enhanced sodium channel inhibition in atrial tissue at clinically relevant concentrations [4]. This atrial selectivity makes ranolazine particularly valuable for managing atrial arrhythmias while minimizing unwanted effects on ventricular function.

The use-dependent nature of ranolazine's sodium channel blockade becomes particularly relevant during tachyarrhythmias, where increased activation frequency results in greater channel inhibition. This **frequency-dependent inhibition** is more pronounced in atrial tissue due to its higher intrinsic firing rates during arrhythmias, providing an additional element of atrial selectivity [4]. Electrophysiological studies have also demonstrated that ranolazine produces voltage-dependent instantaneous inhibition in both atrial and ventricular myocytes, causing a negative shift in the voltage of half-maximal inactivation and slowing the recovery of I_{Na} from inactivation in both cell types [4]. These effects contribute to the drug's ability to prolong the atrial effective refractory period, particularly in the setting of arrhythmogenic conditions such as atrial fibrillation.

Experimental Protocols and Methodologies

Whole-Cell Voltage Clamp Techniques

The investigation of ranolazine's effects on cardiac sodium channels primarily relies on **whole-cell voltage clamp** methodology, which allows precise measurement of ion currents under controlled conditions. For studies of the fast sodium current (I_{Na}), recordings are typically performed at room temperature ($\sim 22^{\circ}\text{C}$) using symmetrical internal and external sodium concentrations (5 mM) to optimize current resolution and voltage control [4]. The late sodium current (I_{NaL}) is often recorded using elevated external sodium concentrations (70 mM) with maintained internal sodium (5 mM) to enhance the detection of this small, persistent current [4]. To specifically isolate and study I_{NaL} , researchers often employ the sea anemone toxin ATX-II (at concentrations of 3 nM), which enhances late sodium current by impairing channel inactivation, thereby allowing more accurate quantification of drug effects on this pathophysiologically important current [1] [4].

A standard voltage clamp protocol for assessing ranolazine's effects on I_{Na} involves holding cells at -120 mV to ensure complete recovery from inactivation, followed by depolarizing test pulses to various potentials (typically from -80 mV to $+60$ mV in 5 mV increments) to assess current-voltage relationships [4]. The voltage dependence of inactivation is determined using a two-pulse protocol where conditioning prepulses (ranging from -150 mV to -50 mV) precede a fixed test pulse to -20 mV [4]. Use-dependent block is evaluated by applying trains of pulses at varying frequencies (e.g., 0.2 Hz to 10 Hz) and comparing current reduction during the train to the first pulse in the series [2]. For concentration-response studies, cells are exposed to increasing concentrations of ranolazine (typically ranging from 1 μ M to 300 μ M) to determine IC_{50} values for both peak I_{Na} and I_{NaL} inhibition [2] [4].

Structural Biology Approaches

The structural characterization of ranolazine binding to NaV1.5 employs **cryogenic electron microscopy** (cryo-EM) techniques, which have revolutionized the study of membrane protein-drug interactions. The experimental workflow begins with overexpression and purification of recombinant NaV1.5 channels in HEK293 cells in the presence of ranolazine and essential intracellular binding partners including fibroblast growth-factor homology factor 12B (FGF12B) and calmodulin [2]. The resulting protein-drug complex is purified using affinity chromatography and size exclusion chromatography to obtain a homogeneous sample suitable for structural studies [2]. This purified complex is then applied to cryo-EM grids, vitrified using liquid ethane, and imaged under cryogenic conditions to preserve native structure [2].

Data processing typically involves collecting thousands of micrographs, from which particle images are automatically selected and subjected to two-dimensional and three-dimensional classification to identify homogeneous particle subsets [2]. For the ranolazine-NaV1.5 complex, one study analyzed $2,154,834$ particles to yield $165,532$ particles used for final three-dimensional reconstruction at a resolution of 3.2 Å [2]. This resolution allows precise modeling of the drug-binding site and identification of specific molecular interactions between ranolazine and channel residues. Mutagenesis studies complement the structural data by systematically altering identified contact residues (e.g., F1762 in DIV, F403 in DI) and quantitatively assessing the effects on ranolazine binding and channel block using electrophysiological techniques [2]. This combined structural and functional approach provides a comprehensive understanding of the molecular basis of ranolazine's mechanism of action.

Table 2: Key Experimental Protocols for Studying Ranolazine Mechanisms

Methodology	Key Parameters	Applications	Technical Considerations
Whole-cell voltage clamp	Symmetrical low [Na ⁺] (5 mM) for INa; High external [Na ⁺] (70 mM) for INaL	Quantification of current inhibition, use-dependence, voltage-dependence	Temperature control critical for kinetics; series resistance compensation essential
Cryo-EM structural analysis	3.2 Å resolution; 165,532 particles in final reconstruction	Determining drug-binding site, conformational changes	Requires channel stabilization with FHF12B and calmodulin; extensive particle classification
Mutagenesis & electrophysiology	Alanine scanning of DI (Q372, F403) and DIV (L1464, F1762) residues	Identifying critical binding interactions	Combine with molecular modeling to interpret effects on drug binding
Langendorff-perfused heart	Atrial effective refractory period, conduction velocity measurements	Assessing tissue-level antiarrhythmic effects	Allows study of rate-dependent effects in intact tissue preparation

Therapeutic Implications and Emerging Applications

Clinical Applications in Cardiovascular Disease

Ranolazine has established efficacy in the management of **chronic stable angina**, where it provides symptomatic improvement without the hemodynamic effects typically associated with traditional antianginal agents. Clinical trials including MARISA (Monotherapy Assessment of Ranolazine In Stable Angina) and CARISA (Combination Assessment of Ranolazine in Stable Angina) have demonstrated that ranolazine significantly improves exercise performance, delays the onset of angina, and reduces the frequency of angina attacks [1]. Importantly, these antianginal effects occur without clinically meaningful changes in heart rate or blood pressure, making it particularly valuable for patients who cannot tolerate the hemodynamic consequences of traditional antianginal drugs [1]. More recent research has also confirmed its efficacy in specialized populations, such as patients with **coronary slow flow phenomenon**, where a 2025 randomized

controlled trial demonstrated significant improvement in clinical symptoms and quality of life measures after two months of treatment with ranolazine 500 mg twice daily [7].

Beyond its antianginal effects, ranolazine demonstrates significant **antiarrhythmic properties**, particularly in the management of atrial fibrillation. The MERLIN-TIMI 36 trial, which evaluated ranolazine in patients with acute coronary syndromes, revealed potential antiarrhythmic effects with a lower incidence of arrhythmias compared to placebo [1]. Subsequent research has confirmed that ranolazine is effective for both conversion of recent-onset atrial fibrillation and maintenance of sinus rhythm, often in combination with other antiarrhythmic agents such as dronedarone and amiodarone [2] [3]. The atrial-selective nature of its sodium channel blockade provides a favorable therapeutic index, offering antiarrhythmic efficacy without significant ventricular proarrhythmia [4]. This dual benefit for both angina and arrhythmias makes ranolazine particularly valuable for patients with complex cardiovascular disease.

Emerging Non-Cardiovascular Applications

Recent research has revealed several **pleiotropic effects** of ranolazine that extend beyond its cardiovascular applications. Preclinical studies have identified potential **anticancer properties**, with evidence that ranolazine can inhibit tumor invasion and metastasis in various cancer models including breast, colorectal, and prostate cancer [5]. The proposed mechanism involves inhibition of sodium channels expressed in cancer cells (particularly Nav1.5), which are known to promote invasion and metastatic behavior [5]. In breast cancer models, ranolazine has been shown to repress the pro-invasive phenotype of MDA-MB-231 cells and reduce extracellular matrix degradation activity, with effects observed at concentrations as low as 2.5 μM during hypoxia [5]. Similar anti-invasive effects have been demonstrated in colorectal and prostate cancer models, with one study showing a 63% reduction in lung metastasis in a rat prostate cancer model following ranolazine administration [5].

Additional emerging applications include potential **metabolic effects**, with several clinical studies reporting improvements in glycemic control in patients with diabetes [8]. The proposed mechanisms for these metabolic benefits include β -cell preservation, inhibition of hepatic glucose secretion, and enhancement of glucose-dependent insulin secretion [8]. Ranolazine has also demonstrated **organ protective effects** in preclinical models, showing potential nephroprotective, hepatoprotective, and neuroprotective properties through modulation of various cellular pathways including TNF- α , NF- κB , Caspase-3, and IL-1 β [5]. These

diverse pharmacological effects underscore the complexity of ranolazine's actions beyond its classic late sodium current inhibition and suggest potential for therapeutic repurposing in various disease states.

Conclusion

Need Custom Synthesis?

Email: info@smolecule.com or Request Quote Online.

References

1. of the new anti-ischemia drug Mechanism - PMC of action ranolazine [pmc.ncbi.nlm.nih.gov]
2. Structural basis for inhibition of the cardiac sodium by the... channel [pmc.ncbi.nlm.nih.gov]
3. Structural basis for inhibition of the cardiac sodium by the... channel [nature.com]
4. Inhibition of voltage-gated Na⁺ currents by eleclazine in rat atrial and... [pmc.ncbi.nlm.nih.gov]
5. SEBM | Unraveling the pharmacological and therapeutic potential of... [ebm-journal.org]
6. Monograph for Professionals - Drugs.com Ranolazine [drugs.com]
7. a randomized, double-blind, placebo-controlled clinical trial [pubmed.ncbi.nlm.nih.gov]
8. The Effect of Ranolazine on Glycemic Control: a Narrative Review to... [link.springer.com]

To cite this document: Smolecule. [Comprehensive Technical Analysis of Ranolazine's Mechanism of Action: Late Sodium Current Inhibition]. Smolecule, [2026]. [Online PDF]. Available at: [https://www.smolecule.com/products/b3353457#ranolazine-mechanism-of-action-late-sodium-current-inhibition]

Disclaimer & Data Validity:

The information provided in this document is for Research Use Only (RUO) and is strictly not intended for diagnostic or therapeutic procedures. While Smolecule strives to provide accurate protocols, we make no

warranties, express or implied, regarding the fitness of this product for every specific experimental setup.

Technical Support: The protocols provided are for reference purposes. Unsure if this reagent suits your experiment? [Contact our Ph.D. Support Team for a compatibility check]

Need Industrial/Bulk Grade? Request Custom Synthesis Quote

Smolecule

Your Ultimate Destination for Small-Molecule (aka. smolecule) Compounds, Empowering Innovative Research Solutions Beyond Boundaries.

Contact

Address: Ontario, CA 91761, United States

Phone: (512) 262-9938

Email: info@smolecule.com

Web: www.smolecule.com