

S55746 cell culture apoptosis assay protocol

Author: Smolecule Technical Support Team. **Date:** February 2026

Compound Focus: s55746

CAS No.: 1448525-91-4

Cat. No.: S3316415

[Get Quote](#)

Introduction to S55746

S55746 (also known as BCL201) is a novel, orally bioavailable small-molecule inhibitor that selectively and potently targets the anti-apoptotic protein BCL-2 [1] [2]. It functions as a BH3-mimetic, meaning it displaces pro-apoptotic proteins like BAX from their binding site on BCL-2's hydrophobic groove, thereby initiating the mitochondrial pathway of apoptosis [1] [3]. This makes it a promising candidate for anti-cancer research, particularly in hematological malignancies where BCL-2 is overexpressed.

Mechanism of Action

S55746 specifically binds to BCL-2 with high affinity, freeing pro-apoptotic proteins to trigger mitochondrial outer membrane permeabilization (MOMP) [4] [5]. This leads to cytochrome c release, activation of caspase proteases, and execution of apoptosis. The following diagram illustrates this intrinsic apoptosis pathway.

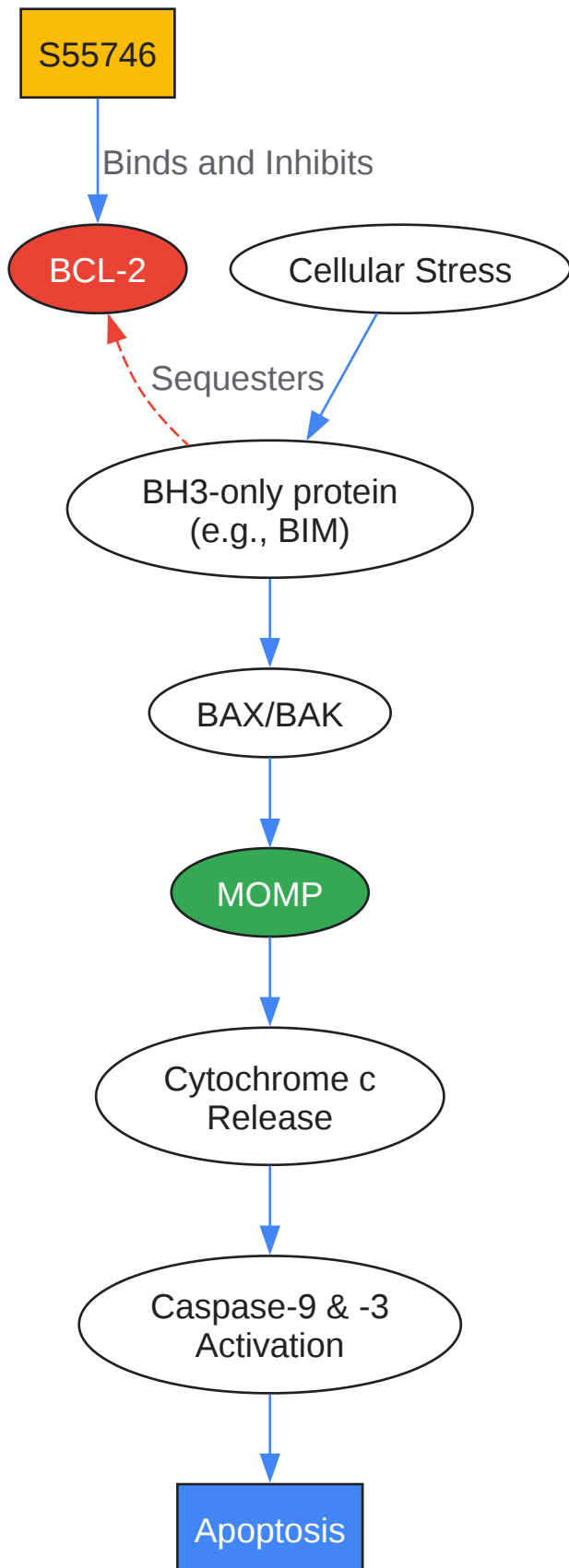

[Click to download full resolution via product page](#)

Biochemical and Cellular Profiling of S55746

The tables below summarize key quantitative data on the binding affinity, selectivity, and cellular cytotoxicity of S55746.

Table 1: Binding Affinity and Selectivity Profile of S55746 [1]

Target Protein	Assay Type	Affinity (K_i or K_D)	Selectivity (vs. BCL-2)
BCL-2	Fluorescence Polarisation (FP)	$K_i = 1.3 \text{ nM}$	—
BCL-XL	Fluorescence Polarisation (FP)	$K_i = 520 \text{ nM}$	~400-fold
MCL-1	Fluorescence Polarisation (FP)	No significant binding (4.3% inhibition at 30 μM)	Not applicable
BFL-1	Fluorescence Polarisation (FP)	No significant binding (7.4% inhibition at 5 μM)	Not applicable

Table 2: In Vitro Cytotoxic Activity (IC_{50}) in Hematological Cell Lines [1] [6]

Cell Line	Cancer Type	BCL-2 Family Dependency	S55746 IC_{50} (72h treatment)
RS4;11	Acute Lymphoblastic Leukemia (ALL)	BCL-2-dependent	71.6 nM
H146	Small Cell Lung Carcinoma	BCL-XL-dependent	1.7 μM

Detailed Experimental Protocols

Here are detailed protocols for assessing **S55746**-induced apoptosis in cell culture, based on the hallmarks of apoptosis measured in the original research [1].

Protocol 1: Annexin V/Propidium Iodide (PI) Staining for Apoptosis

This protocol detects phosphatidylserine externalization, an early marker of apoptosis [1] [7].

Workflow Overview

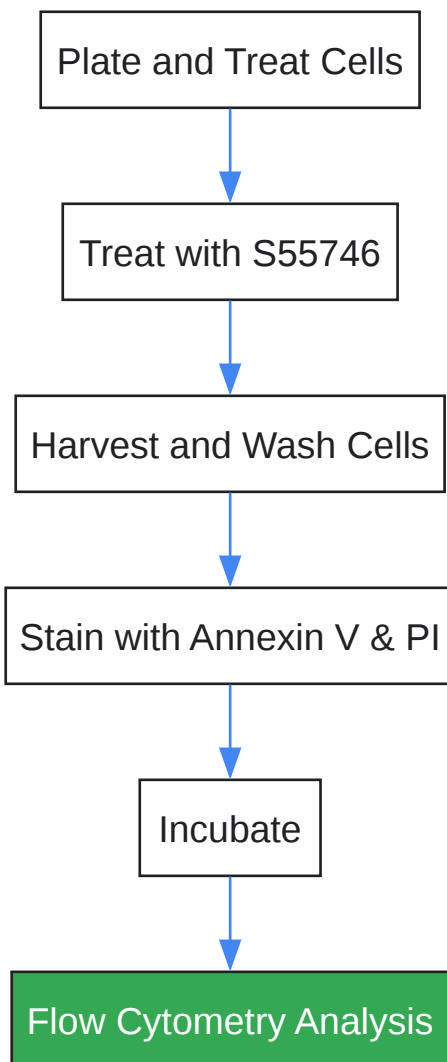

[Click to download full resolution via product page](#)

Materials

- **Cells:** BCL-2-dependent cell line (e.g., RS4;11) [1].
- **Compound:** **S55746**, prepared as a 100 mg/mL stock in DMSO [6].
- **Kit:** Alexa Fluor 488 Annexin V/Dead Cell Apoptosis Kit (or equivalent), containing [7]:
 - Alexa Fluor 488 annexin V
 - Propidium Iodide (PI) solution
 - 5X Annexin-binding buffer
- **Other:** Cell culture medium, phosphate-buffered saline (PBS), flow cytometer.

Procedure

- **Cell Preparation and Treatment:** Plate cells at an appropriate density (e.g., $0.5-1 \times 10^6$ cells/mL). The next day, treat with a range of **S55746** concentrations (e.g., **0.01 to 1 μ M**) for **24 to 72 hours**. Include a vehicle control (DMSO at the same concentration as treated groups) [1] [6].
- **Harvesting Cells:** Collect both suspended and adherent cells. Wash cells once with cold PBS.
- **Staining:** Resuspend cell pellet in 100 μ L of 1X Annexin-binding buffer. Add **5 μ L of Alexa Fluor 488 annexin V** and **1 μ L of PI** (from a 100 μ g/mL working solution) [7].
- **Incubation:** Incubate at room temperature for **15 minutes in the dark**.
- **Analysis:** Add 400 μ L of 1X Annexin-binding buffer and analyze by flow cytometry within 1 hour. Use the following gating strategy:
 - **Viable cells:** Annexin V⁻/PI⁻
 - **Early apoptotic cells:** Annexin V⁺/PI⁻
 - **Late apoptotic/necrotic cells:** Annexin V⁺/PI⁺

Protocol 2: Western Blot Analysis of Apoptosis Markers

This protocol confirms apoptosis by detecting the cleavage of key effector proteins, such as caspase-3 and its substrate PARP [1].

Workflow Overview

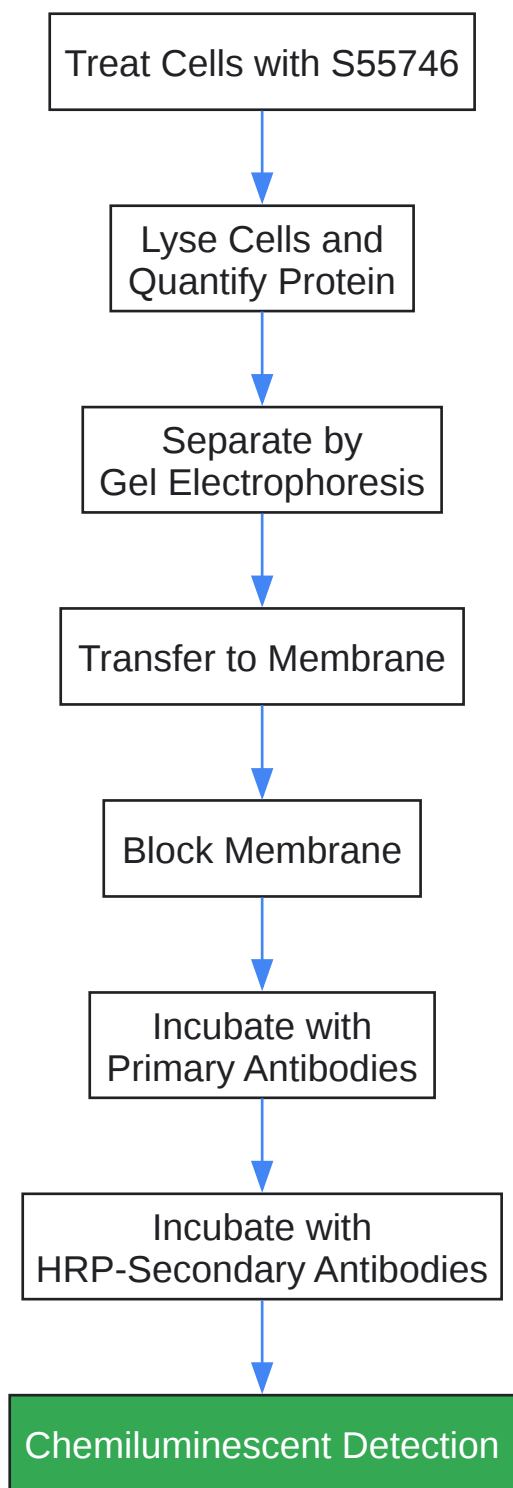

[Click to download full resolution via product page](#)

Materials

- **Cells and Compound:** As in Protocol 1.
- **Antibodies:**

- Anti-Cleaved Caspase-3
- Anti-PARP (to detect full-length and cleaved fragments)
- Anti- β -Actin (or other loading control)
- HRP-conjugated secondary antibodies.
- **Other:** RIPA lysis buffer, protease inhibitors, BCA protein assay kit, SDS-PAGE gel, PVDF or nitrocellulose membrane, chemiluminescent substrate.

Procedure

- **Cell Treatment and Lysis:** Treat cells with **S55746** (e.g., **0.1 to 1 μ M** for **2 to 24 hours**). Wash cells with PBS and lyse on ice using RIPA buffer supplemented with protease inhibitors.
- **Protein Separation and Transfer:** Determine protein concentration. Separate equal amounts of protein (e.g., 20-30 μ g) by **SDS-PAGE** and transfer to a membrane.
- **Antibody Incubation:** Block the membrane with 5% non-fat milk. Incubate with primary antibodies overnight at 4°C, followed by incubation with appropriate HRP-conjugated secondary antibodies.
- **Detection:** Develop the blot using a chemiluminescent substrate. Expected results include:
 - Appearance of a **Cleaved Caspase-3** band.
 - Decrease in **full-length PARP** and appearance of a smaller **cleaved PARP fragment**.

Key Application Notes

- **Cell Line Selection:** The efficacy of **S55746** is highly dependent on the expression of BCL-2 in the cell line. Always confirm the dependency profile of your model system. The RS4;11 cell line serves as an excellent positive control [1].
- **Optimization is Crucial:** The provided concentrations and timings are starting points. Perform dose-response and time-course experiments to establish optimal conditions for your specific research context.
- **Control Experiments:** To confirm the specificity of **S55746**, its lack of cytotoxicity in BCL-XL-dependent cell lines (like H146) can be demonstrated [1].
- **Safety:** Propidium iodide is a potential mutagen. Please use appropriate precautions when handling [7].

Need Custom Synthesis?

Email: info@smolecule.com or [Request Quote Online](#).

References

1. S55746 is a novel orally active BCL-2 selective and potent ... [pmc.ncbi.nlm.nih.gov]
2. S55746 is a novel orally active BCL-2 selective and potent ... [oncotarget.com]
3. S55746 is a novel orally active BCL-2 selective and potent ... [oncotarget.com]
4. The BCL2 family: from apoptosis mechanisms to new ... [nature.com]
5. Apoptosis: A Comprehensive Overview of Signaling Pathways ... [pmc.ncbi.nlm.nih.gov]
6. S55746 | Bcl-2 inhibitor | Mechanism | Concentration [selleckchem.com]
7. Alexa Fluor 488 Annexin V/Dead Cell Kit Apoptosis [thermofisher.com]

To cite this document: Smolecule. [S55746 cell culture apoptosis assay protocol]. Smolecule, [2026]. [Online PDF]. Available at: [<https://www.smolecule.com/products/b3316415#s55746-cell-culture-apoptosis-assay-protocol>]

Disclaimer & Data Validity:

The information provided in this document is for Research Use Only (RUO) and is strictly not intended for diagnostic or therapeutic procedures. While Smolecule strives to provide accurate protocols, we make no warranties, express or implied, regarding the fitness of this product for every specific experimental setup.

Technical Support: The protocols provided are for reference purposes. Unsure if this reagent suits your experiment? [Contact our Ph.D. Support Team for a compatibility check]

Need Industrial/Bulk Grade? Request Custom Synthesis Quote

Smolecule

Your Ultimate Destination for Small-Molecule (aka. smolecule) Compounds, Empowering Innovative Research Solutions Beyond Boundaries.

Contact

Address: Ontario, CA 91761, United States

Phone: (512) 262-9938

Email: info@smolecule.com

Web: www.smolecule.com