

diallyl oxalate radical decarboxylation reactions

Author: Smolecule Technical Support Team. **Date:** February 2026

Compound Focus: Diallyl oxalate

CAS No.: 615-99-6

Cat. No.: S1929053

Get Quote

Scientific Background and Mechanism

Radical decarboxylation of oxalate esters is a powerful method for generating carbon-centered radicals under mild conditions. The reaction typically involves the homolytic cleavage of the C-C bond adjacent to the oxalate moiety, releasing CO₂ and forming an alkyl radical that can participate in various transformations [1]. While your specific interest in **diallyl oxalate** is not documented, the general mechanism for allylic oxalate radicals is well-established.

The diagram below illustrates the general mechanism and key intermediates for the radical decarboxylation of an allylic oxalate ester:

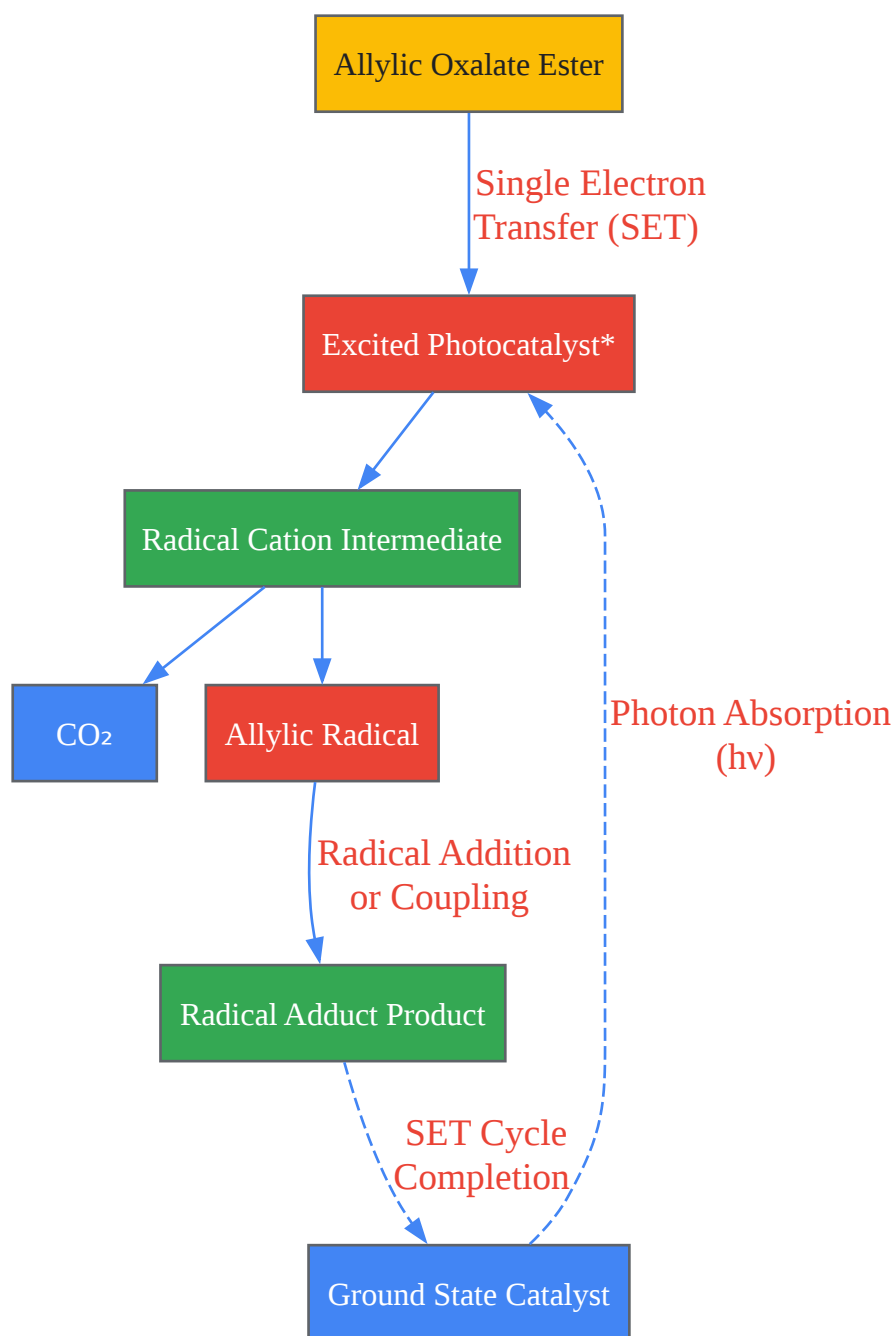

Mechanism of Photoredox Radical Decarboxylation

[Click to download full resolution via product page](#)

Experimental Protocol: General Procedure for Radical Decarboxylation

This protocol is adapted from published procedures for allylic oxalate systems [2] [1] and can be modified for **diallyl oxalate**.

Reagents and Materials

- **Substrate:** **Diallyl oxalate** (synthesized via standard esterification procedures)
- **Photocatalyst:** Ir[dF(CF₃)ppy]₂(dtbbpy)PF₆ (1-2 mol%)
- **Solvent:** Anhydrous dichloromethane (DCM) or acetonitrile
- **Reaction partners:** Electron-deficient alkenes, aryl halides, or other radical traps
- **Light source:** Blue LEDs (450-455 nm)
- **Inert atmosphere:** Nitrogen or argon

Step-by-Step Procedure

- **Reaction Setup**
 - In a dried Schlenk tube, combine **diallyl oxalate** (1.0 equiv) and photocatalyst (1-2 mol%)
 - Add chosen radical trap (1.2-2.0 equiv)
 - Purge with inert gas (N₂ or Ar) for 10-15 minutes
 - Add anhydrous solvent under inert atmosphere
- **Reaction Execution**
 - Stir reaction mixture under blue LED irradiation at room temperature
 - Monitor reaction progress by TLC or LC-MS
 - Typical reaction time: 4-16 hours
- **Workup Procedure**
 - Concentrate reaction mixture under reduced pressure
 - Purify crude product by flash chromatography
 - Analyze products by NMR, MS, and other characterization methods

Key Optimization Parameters

Parameter	Optimal Conditions	Effect of Variation
Catalyst Loading	1-2 mol%	<1%: Incomplete conversion; >2%: Potential side reactions
Solvent	Anhydrous DCM	Acetonitrile: Faster but may promote side reactions
Light Source	Blue LEDs (450-455 nm)	Green light: Slower reaction; UV: Decomposition
Concentration	0.05-0.1 M	Higher: Dimerization; Lower: Extended reaction times
Temperature	Room temperature	Elevated: Reduced selectivity

Critical Experimental Considerations

- **Oxygen Exclusion**

- Rigorously exclude oxygen throughout the process
- Use standard Schlenk techniques or glovebox
- Even trace oxygen can quench radical intermediates

- **Oxalate Stability**

- **Diallyl oxalate** may be prone to hydrolysis
- Use anhydrous conditions and molecular sieves if necessary
- Prepare immediately before use or store under inert atmosphere

- **Radical Trap Selection**

- Michael acceptors (acrylates, maleimides) work efficiently
- Electron-deficient aromatics may require optimized conditions
- Strain-activated systems (vinyl cyclopropanes) show enhanced reactivity

Analytical Methods and Characterization

Analysis Type	Expected Key Features	Diagnostic Utility
^1H NMR	Disappearance of oxalate signals (~4.5-5.0 ppm)	Confirm decarboxylation
^{13}C NMR	Absence of carbonyl signals (~155-160 ppm)	Reaction completion
IR Spectroscopy	Decrease in C=O stretch (~1740 cm^{-1})	Monitor progress
GC-MS / LC-MS	Molecular ion corresponding to adduct	Product identification
EPR Spectroscopy	Detection of radical intermediates	Mechanistic studies

Application in Synthetic Chemistry

The radical decarboxylation of oxalate esters has been successfully applied to several challenging synthetic transformations [1]:

- **Construction of all-carbon quaternary centers** through tertiary radical coupling
- **Complex molecule synthesis** including natural products like Chelovidene A and Dendrillolide C
- **Tandem cyclization sequences** for rapid assembly of carbocyclic frameworks

The experimental workflow for these applications typically follows this pattern:

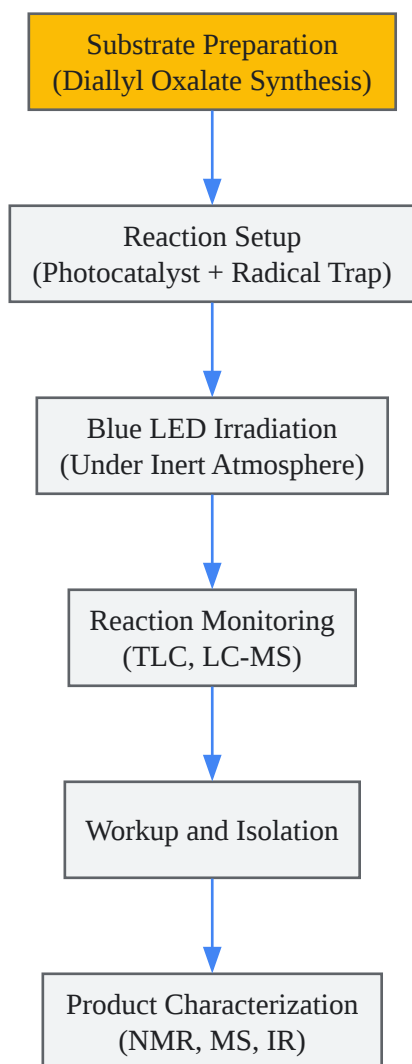

Experimental Workflow for Radical Decarboxylation

[Click to download full resolution via product page](#)

Safety and Environmental Considerations

- **Photocatalyst compounds** may be expensive and require appropriate handling
- **Proper eye protection** is essential when working with high-intensity LEDs
- **Standard laboratory safety practices** for organic synthesis should be followed
- **Waste disposal** should follow institutional guidelines for metal-containing compounds

Conclusion

While specific literature on **diallyl oxalate** radical decarboxylation is limited, the well-established principles of oxalate ester photochemistry provide a solid foundation for developing this methodology. The protocol outlined above can serve as a starting point for optimization, with particular attention to the unique reactivity of the diallyl system.

Reference List

- PMC Article on Oxalate Decarboxylase Mechanisms (2021) - Electron transfer mechanisms [3]
- Beilstein Journal of Organic Chemistry (2023) - Photoredox catalysis applications [2]
- Journal of Physics and Chemistry Research (2020) - Oxalate half-esters in synthesis [1]
- ScienceDirect Topics - Oxalate Decarboxylase Overview [4] [5]
- PMC Applied Studies in HEK293 Cells (2017) - Biological applications [6]

Need Custom Synthesis?

Email: info@smolecule.com or Request Quote Online.

References

1. Oxalate Half-Esters and Their Derivatives [pubtexto.com]
2. BJOC - Photoredox catalysis enabling decarboxylative radical ... [beilstein-journals.org]
3. Oxalate decarboxylase uses electron hole hopping for catalysis [pmc.ncbi.nlm.nih.gov]
4. sciencedirect.com/topics/medicine-and-dentistry/ oxalate - decarboxylase [sciencedirect.com]
5. Oxalate Decarboxylase - an overview [sciencedirect.com]
6. Expression of heterologous oxalate decarboxylase in ... [pmc.ncbi.nlm.nih.gov]

To cite this document: Smolecule. [diallyl oxalate radical decarboxylation reactions]. Smolecule, [2026]. [Online PDF]. Available at: [<https://www.smolecule.com/products/b1929053#diallyl-oxalate-radical-decarboxylation-reactions>]

Disclaimer & Data Validity:

The information provided in this document is for Research Use Only (RUO) and is strictly not intended for diagnostic or therapeutic procedures. While Smolecule strives to provide accurate protocols, we make no warranties, express or implied, regarding the fitness of this product for every specific experimental setup.

Technical Support: The protocols provided are for reference purposes. Unsure if this reagent suits your experiment? [Contact our Ph.D. Support Team for a compatibility check]

Need Industrial/Bulk Grade? Request Custom Synthesis Quote

Smolecule

Your Ultimate Destination for Small-Molecule (aka. smolecule) Compounds, Empowering Innovative Research Solutions Beyond Boundaries.

Contact

Address: Ontario, CA 91761, United States

Phone: (512) 262-9938

Email: info@smolecule.com

Web: www.smolecule.com