

troubleshooting GC-MS for ketone analysis

Author: Smolecule Technical Support Team. **Date:** February 2026

Compound Focus: 2-Methyl-4-octanone

CAS No.: 7492-38-8

Cat. No.: S1896240

Get Quote

GC-MS Troubleshooting Guide

Here is a structured table of common symptoms, potential causes, and solutions specifically useful for trace-level and ketone analysis, based on recent case studies and expert workshops.

Symptom	Potential Cause	Diagnostic Steps	Solution
Erratic peak shapes, high baseline, signal "blobs" or "grass" [1]	Severe ion source contamination; Faulty calibration valve [1]	Check for recent vacuum leaks; Perform manual tune to observe signal stability; Listen for calibration valve operation [1].	Clean or replace ion source; Replace faulty calibration valve [1].
Failure to autotune; requires very high detector voltage [1]	Problems with ion production/transmission; Faulty filament; Issues with ion optics [1]	Confirm stable vacuum; Replace filament; Check if ions reach detector in manual tune mode [1].	Service ion optics; Replace faulty components (may require professional service) [1].

Symptom	Potential Cause	Diagnostic Steps	Solution
Poor sensitivity for volatile compounds (VVOCs) [2]	Inefficient trapping on sorbent tube; Use of standard VOC tubes for VVOCs [2]	Review sampling method; Check if target compounds are outside the sorbent's volatility range [2].	Use multi-bed sorbent tubes (e.g., Carbograp 5 TD) designed for VVOCs [2].
Rising helium costs or supply issues [2]	Helium price volatility and supply instability [2]	Evaluate carrier gas options with your instrument manufacturer.	Switch to hydrogen as a carrier gas; Use a HydroInert Source to maintain sensitivity [2].
Poor sensitivity and resolution for complex samples [3]	Suboptimal method parameters; Incorrect column selection [3]	Review sample preparation, column type, and temperature program [3].	Optimize method: use QuEChERS, select appropriate column, use temperature programming, and optimize ion source [3].

Detailed Experimental Protocol: Reliable Ketone Analysis by TD-GC-MS

For reliable analysis of volatile organic compounds like ketones, **Thermal Desorption (TD)** coupled with GC-MS is a powerful technique. The following protocol, drawing from the analysis of very volatile organic compounds (VVOCs) in indoor air, provides a robust methodology [2].

Sample Collection and Sorbent Selection

- **Choosing Sorbent Tubes:** For reliable capture of volatile ketones and other VVOCs, standard sorbent tubes like Tenax are insufficient. Use **multi-bed sorbent tubes**, such as those packed with **Carbograp 5 TD** [2].
- **Sampling Strategy:** The selection depends on your sample matrix (air, solid, liquid), the analytical question, and the expected concentration [2]. For indoor air sampling, a protocol from experts at Germany's IFA is to **open all windows before starting and take VOC samples first** [2].

Instrumental Setup: TD-GC-MS

- **Thermal Desorption:** A two-stage desorption process is used to transfer the sample to the GC, which significantly boosts sensitivity [2].
- **GC-MS Configuration:**
 - **Carrier Gas:** Hydrogen can be an effective and economical alternative to helium. Using a specialized source (e.g., Agilent's **HydroInert Source**) allows operation without compromising data quality [2].
 - **Data Processing:** Use software deconvolution tools (e.g., in Agilent's MassHunter) for clearer data and more accurate peak identification in complex matrices [2].

Method Optimization and Maintenance

- **Routine Maintenance:** Perform regular maintenance, including cleaning the ion source and replacing worn parts, to maintain instrument performance and data quality [3].
- **Method Validation:** Always include a validation process for your specific method, establishing limits of detection, quantitation, and precision, as demonstrated in environmental monitoring methods [2].

Frequently Asked Questions (FAQs)

- **What is the most systematic way to diagnose a GC-MS that fails to tune?** Begin by confirming a stable vacuum. Then, methodically check components: replace the filament, perform a manual tune to see if ions reach the detector, and verify the operation of the calibration valve by listening for its click and observing a corresponding spike in pressure or the mass 28 signal [1].
- **Can hydrogen really replace helium as a carrier gas for sensitive applications?** Yes. With the proper hardware (e.g., an Agilent HydroInert Source), hydrogen can be used as a carrier gas without losing sensitivity or data quality. This is approved for use with sensitive methods like EPA TO-15 [2].
- **My ketone analysis lacks sensitivity. What should I check first?** First, review your sampling and sample introduction. For air analysis, ensure you are using multi-bed sorbent tubes designed for VVOCs, not standard VOC tubes [2]. For liquid injections, optimize your sample preparation (e.g., using SPME or QuEChERS) and check your ion source conditions for contamination [3].

- **How can I improve the quality of my data from complex samples?** Use advanced software features. **Deconvolution tools** can pull apart overlapping peaks in complex chromatograms, leading to clearer data and more confident identification of compounds [2].

Workflow Diagrams

To help visualize the troubleshooting and experimental processes, here are two workflows generated using Graphviz.

Troubleshooting Logic for Tune Failures

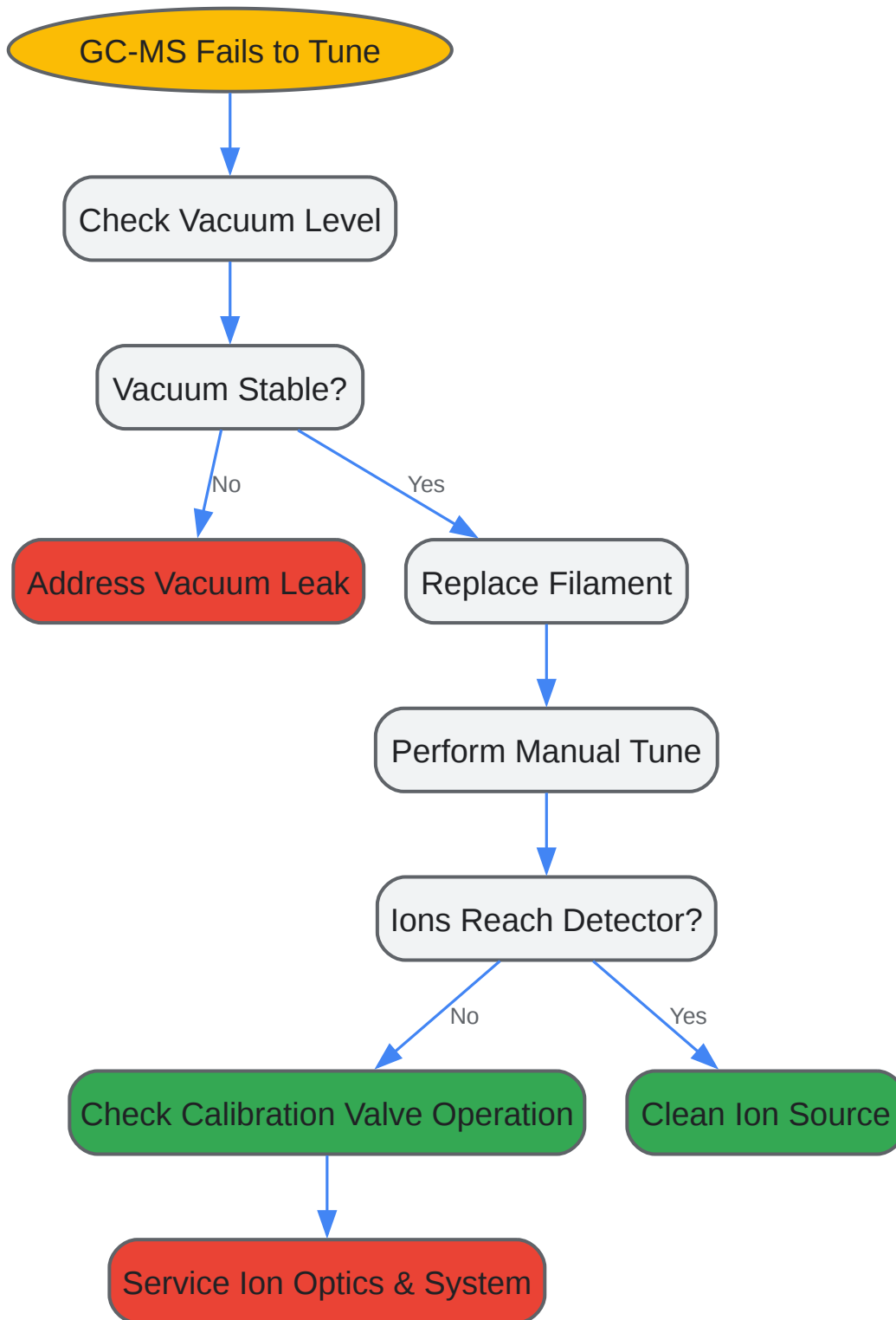

[Click to download full resolution via product page](#)

This diagram outlines a step-by-step diagnostic approach for when a GC-MS instrument fails its autotune, guiding you from initial checks to specific solutions [1].

Workflow for Ketone Analysis via TD-GC-MS

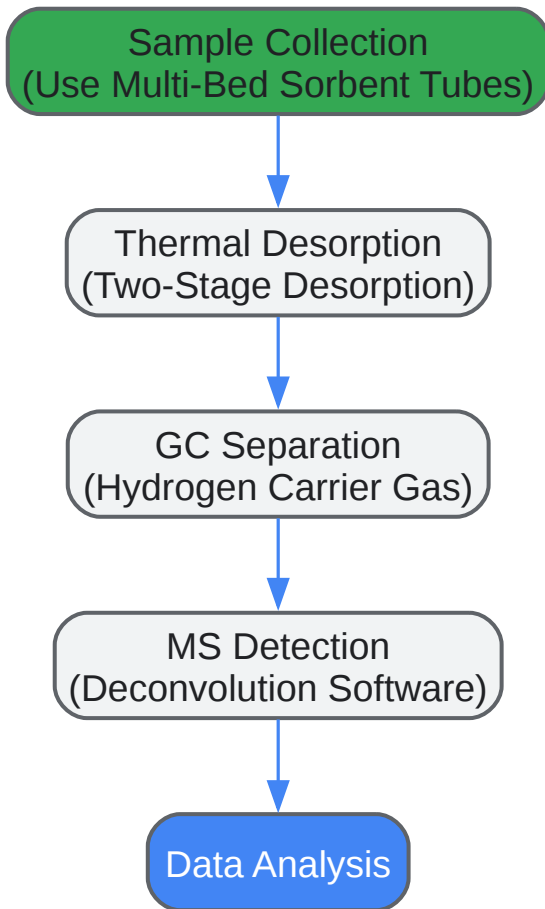

Click to download full resolution via product page

This diagram shows the key stages of a reliable method for analyzing volatile ketones, highlighting critical steps like using the correct sorbent tubes and a hydrogen carrier gas [2].

Need Custom Synthesis?

Email: info@smolecule.com or [Request Quote Online](#).

References

1. - GC Tune Failure Diagnosis: A Case Study | Separation Science MS [sepscience.com]

2. TD– GC – MS for trace volatiles – workshop... | Markes International [markes.com]

3. Mastering GC - MS Techniques [numberanalytics.com]

To cite this document: Smolecule. [troubleshooting GC-MS for ketone analysis]. Smolecule, [2026]. [Online PDF]. Available at: [https://www.smolecule.com/products/b1896240#troubleshooting-gc-ms-for-ketone-analysis]

Disclaimer & Data Validity:

The information provided in this document is for Research Use Only (RUO) and is strictly not intended for diagnostic or therapeutic procedures. While Smolecule strives to provide accurate protocols, we make no warranties, express or implied, regarding the fitness of this product for every specific experimental setup.

Technical Support: The protocols provided are for reference purposes. Unsure if this reagent suits your experiment? [Contact our Ph.D. Support Team for a compatibility check]

Need Industrial/Bulk Grade? Request Custom Synthesis Quote

Smolecule

Your Ultimate Destination for Small-Molecule (aka. smolecule) Compounds, Empowering Innovative Research Solutions Beyond Boundaries.

Contact

Address: Ontario, CA 91761, United States

Phone: (512) 262-9938

Email: info@smolecule.com

Web: www.smolecule.com