

# Taplucainium research applications beyond chronic cough

**Author:** Smolecule Technical Support Team. **Date:** February 2026

## Compound Focus: Taplucainium Chloride

CAS No.: 2489565-37-7

Cat. No.: S12865047

[Get Quote](#)

## Taplucainium Application Notes & Research Proposals

**1. Drug Profile and Core Mechanism of Action** Taplucainium (formerly NTX-1175) is a novel, charged sodium channel blocker developed by Nocion Therapeutics. It belongs to a class of compounds termed "nocions," designed to selectively silence activated nociceptors [1] [2].

- **Mechanism:** Its permanently charged nature prevents passive absorption. It enters nociceptors specifically through large-pore channels (P2X, TRPV, TRPA, TRPM) that open during inflammation or activation. Once inside, it blocks voltage-gated sodium channels ( $Na_v$ ), inhibiting action potential propagation and signal transmission [1] [2].
- **Key Differentiator:** Unlike specific large-pore channel antagonists (e.g., P2X3 antagonists), taplucainium's broader entry mechanism allows it to target a wide range of nociceptor-driven pathologies, irrespective of the specific activating stimulus [2].
- **Safety Profile:** The charged structure minimizes off-target effects and systemic exposure, as it cannot easily cross lipid membranes. Preliminary clinical studies report a favorable safety and tolerability profile [2].

**2. Proposed Research Applications Beyond Chronic Cough** The following table outlines non-chronic cough applications supported by taplucainium's mechanism and early preclinical observations.

Proposed Indication	Therapeutic Rationale	Research Status & Next Steps
<b>Chronic Pruritus (Itch)</b>	Pathological itch is mediated by specific subpopulations of activated nociceptors. Silencing these neurons can inhibit itch signaling without affecting touch sensation.	Early preclinical validation; further studies needed to define efficacy in different itch models (e.g., histaminergic vs. non-histaminergic).
<b>Neuropathic &amp; Inflammatory Pain</b>	Sodium channel blockers are established analgesics. Taplucainium's targeted action could provide pain relief with reduced CNS side effects (sedation, dizziness) common to systemic agents.	Research concept phase. Requires proof-of-concept in standardized pain models (e.g., neuropathic, postoperative).
<b>Other Cough Indications</b>	The mechanism is fundamentally antitussive. Its efficacy may extend to other forms of refractory cough, such as those in IPF or chronic bronchitis.	Phase 2b trial for chronic cough ongoing [1] [2]. Natural extension to other cough etiologies in future clinical phases.

**3. Summary of Quantitative Data** The quantitative data from available sources is summarized in the table below.

Data Category	Results & Findings	Source / Context
<b>Clinical Trial Status</b>	Phase 2b (ASPIRE trial) for chronic cough; approx. 325 patients; randomized, double-blind, placebo-controlled.	Nocion Announcement (2024) [2]
<b>Preclinical Efficacy</b>	"Complete inhibition of cough response" in animal models of cough.	Nocion Presentation (2024) [2]
<b>Clinical Safety</b>	"Favorable safety profile" observed in three early-stage clinical studies.	Nocion Presentation (2024) [2]

#### 4. Detailed Experimental Protocols

**Protocol 1: In Vivo Assessment in a Pruritus Model** This protocol is designed to evaluate the anti-itch efficacy of taplucainium.

- **Objective:** To determine the efficacy and duration of action of taplucainium in suppressing itch-related behaviors in a murine model.
- **Test System:** C57BL/6J mice (n=8-12 per group), with models for both histaminergic (chloroquine) and non-histaminergic (Compound 48/80) itch.
- **Formulation & Administration:**
  - **Drug:** Taplucainium (e.g., 0.1%, 0.3% solutions in saline).
  - **Vehicle Control:** Saline.
  - **Positive Control:** Topical capsaicin or a systemic antipruritic agent.
  - **Dosing:** Intradermal injection (20  $\mu$ L) or topical application (50  $\mu$ L) to the nape of the neck 30 minutes pre-challenge.
- **Challenge & Measurement:**
  - Inject a pruritogen (e.g., 100  $\mu$ g chloroquine in 20  $\mu$ L saline) at the treatment site.
  - Record scratching bouts directed at the injection site for 30-40 minutes post-challenge.
- **Data Analysis:**
  - Compare the mean number of scratching bouts between drug, vehicle, and control groups using a one-way ANOVA with post-hoc test.
  - A significant reduction ( $p < 0.05$ ) in the taplucainium group indicates efficacy.

**Protocol 2: In Vitro Electrophysiology for Target Engagement** This protocol confirms taplucainium's direct mechanism of action on nociceptors.

- **Objective:** To verify that taplucainium selectively inhibits the firing of activated, but not resting, nociceptors.
- **Cell System:** Ex vivo mouse skin-nerve preparation or cultured human iPSC-derived sensory neurons.
- **Stimulation & Recording:**
  - Place the preparation in a recording chamber and superfuse with oxygenated artificial cerebrospinal fluid.
  - Identify nociceptors via mechanical stimulation or response to capsaicin.
  - Apply a pre-treatment superfusate containing a large-pore channel agonist (e.g., ATP for P2X channels) to "open" the pores.
  - Co-apply or sequentially apply taplucainium (e.g., 10  $\mu$ M) during the agonist challenge.
  - Record action potentials using an extracellular suction electrode.
- **Key Metrics:**
  - **Baseline Firing Rate:** In response to agonist alone.
  - **Post-Treatment Firing Rate:** In response to agonist plus taplucainium.
  - **% Inhibition:** Calculate  $(1 - (\text{Firing\_rate\_drug} / \text{Firing\_rate\_baseline})) * 100$ .

- **Data Analysis:**

- Compare firing rates pre- and post-treatment using a paired t-test.
- Successful target engagement is confirmed by a statistically significant reduction in firing rate only when large-pore channels are activated.

## Mechanism and Workflow Visualization

The following diagrams, created with Graphviz, illustrate the drug's mechanism and proposed experimental workflows.

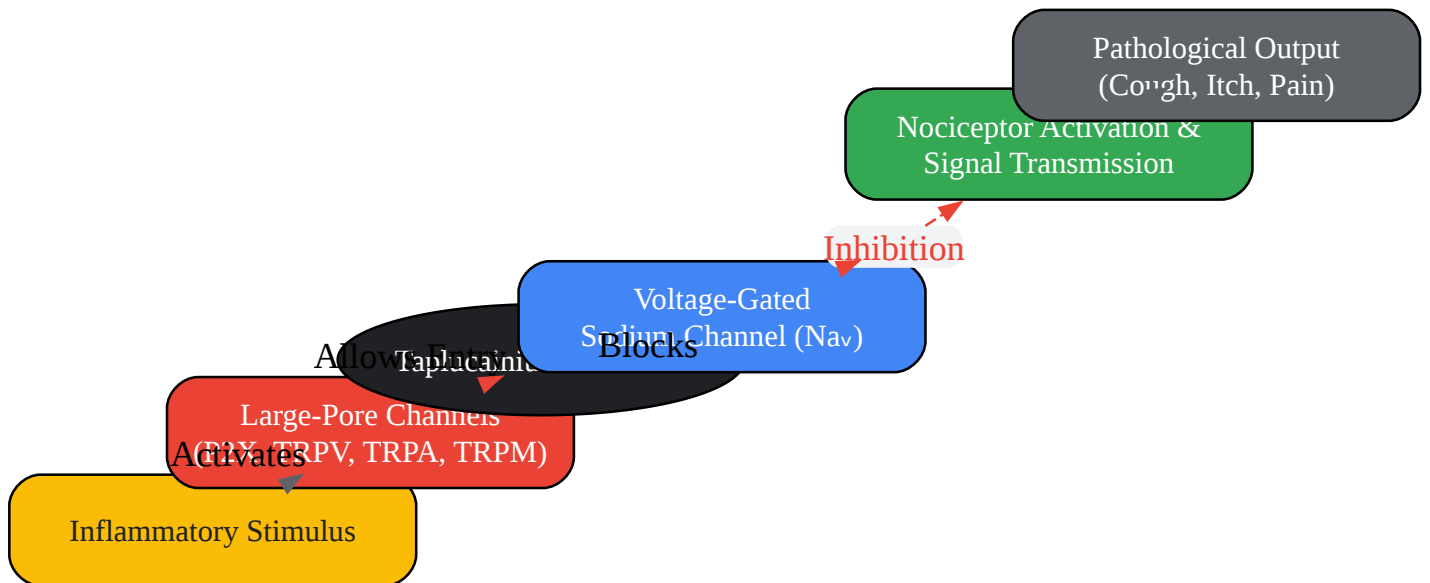

[Click to download full resolution via product page](#)

Diagram 1: Taplucaium's targeted mechanism of action for silencing activated nociceptors.

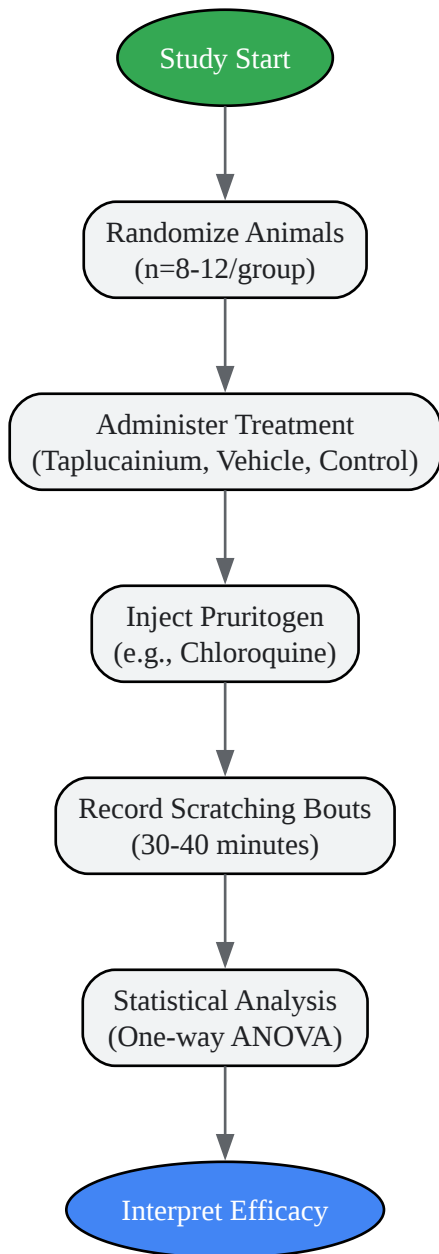

[Click to download full resolution via product page](#)

*Diagram 2: Proposed experimental workflow for evaluating taplucainium in a pruritus model.*

## Key Development Status

It is important to note that while the potential for applications in **itch and pain is supported by a strong mechanistic rationale**, the current clinical development of taplucainium is squarely focused on chronic

cough, with a Phase 2b trial (ASPIRE) ongoing [1] [2]. The proposals for other indications represent promising future research directions rather than confirmed clinical pathways.

### **Need Custom Synthesis?**

Email: [info@smolecule.com](mailto:info@smolecule.com) or [Request Quote Online](#).

## References

1. Taplucanium - Drug Targets, Indications, Patents - Synapse [[synapse.patsnap.com](https://synapse.patsnap.com)]

2. Nocion Therapeutics Presents Data on Preclinical and Clinical... [[businesswire.com](https://www.businesswire.com)]

To cite this document: Smolecule. [Taplucanium research applications beyond chronic cough].

Smolecule, [2026]. [Online PDF]. Available at:

[<https://www.smolecule.com/products/b12865047#taplucanium-research-applications-beyond-chronic-cough>]

### **Disclaimer & Data Validity:**

The information provided in this document is for Research Use Only (RUO) and is strictly not intended for diagnostic or therapeutic procedures. While Smolecule strives to provide accurate protocols, we make no warranties, express or implied, regarding the fitness of this product for every specific experimental setup.

**Technical Support:** The protocols provided are for reference purposes. Unsure if this reagent suits your experiment? [Contact our Ph.D. Support Team for a compatibility check]

**Need Industrial/Bulk Grade?** [Request Custom Synthesis Quote](#)

## Smolecule

Your Ultimate Destination for Small-Molecule (aka. smolecule) Compounds, Empowering Innovative Research Solutions Beyond Boundaries.

### Contact

**Address:** Ontario, CA 91761, United States

**Phone:** (512) 262-9938

**Email:** [info@smolecule.com](mailto:info@smolecule.com)

**Web:** [www.smolecule.com](http://www.smolecule.com)